

Introduction: VERO Technologies

Vero Technologies Limited manufactures and markets the renowned Veroboard prototyping product range, and is a focused business providing an integration, hardware and system integration capability to technology electronics businesses.

The business is dedicated to being a leading provider of a comprehensive range of standard and custom product, enabling it to provide OEMs with rapid deliveries at competitive prices. Vero Technologies believes that every customer is a priority and contact is maintained by means of the organisation's own dedicated Sales Team.

Index

Eurocard Prototyping Boards	3 - 12
Critical Eurocard Dimensions	3
PTH Microboard	4
PTH Square pad board	4
Microboard - double sided	5
Microboard - single sided with grid print	5
3 Plane high density DIP board	6
DIN 41494 Cardframe compatible DIP board	6
DIN 41494 Eurocard: Veroboard pattern	6
Veroboard pattern with collander ground plane	7
Square pad board	7
Square pad board with collander plane	7
Budget Eurocard	8
DIP Boards	8
Plug-in Veroboard	9
DIP Plug-in boards for single and double sided connectors	9
Veroboard - metric pitch	10
Plain Boards - metric and imperial pitch	10
Non-Eurocard Prototyping Boards	11 - 12
Veroboard - single sided copper	11
Verostrip - single sided copper	11
Plain Board	12
DIP Breadboard	12
Eurocard Extender Boards	13 - 14
Double sided extender boards	13
Multilayer extenders	14
Multilayer uncommitted extender boards	15
Eurocard Development Backplanes	16 - 18
Microbus backplanes	16
Double sided uncommitted backplanes	17
Multilayer Microbus backplanes	18
IBM PC and PCI Compatible I/O Brackets	19
Accessories for Prototyping Products	20 - 28
Verowire	20
Card support - ejector mechanism	20
Spot face cutter	20
Terminal assemblies	21
Miniwrap socket pins	22
Miniwrap headed pins	22
Terminal header pin	23
Miniwrap terminal	23
Test point pins	23
Single sided pin	24
Double sided pin	24
Solder terminal pin	24
Solder terminal half pin	24
Part number index	25
SpeedPanel - the fast front panel service	26 - 27

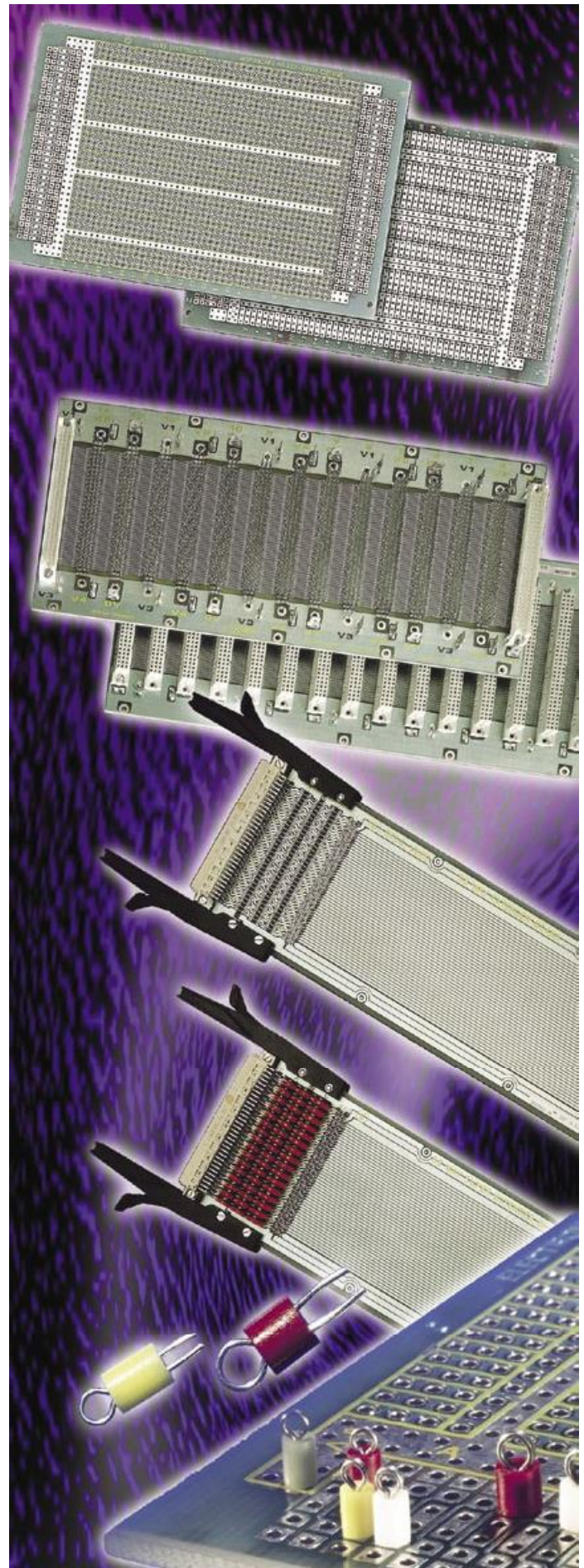

Critical Eurocard dimensions

Critical Eurocard Dimensions

A 2,5mm wide border is necessary - top and bottom of printed circuit boards - to allow clearance for guides and for mounting into plug-in unit guide rails. On the double height Eurocard, owing to the overall size and position of the connectors, it is recommended that when fitting components to front panels the grid as laid out is adopted. This will allow consistency between 3U and 6U height front panels.

List of undrilled pads which appear on most Eurocards

- E.** DIN 41612 connector mounting
- F.** DIN 41617 connector mounting
- G.** Card ejectors
- H.** Card handle Type A - 45,72 centres
- K.** Card handle Type C
- L.** Card handle Type B - 30,48 centres
- M.** Module mounting
- N.** Card mounting brackets KM4 and KM6, card ejector KM6
- O.** KM4 module mounting extended with "M" holes
- P.** Module mounting 220 cards only
- R.** Flexible card handle Type E

Board specifications: Single and Double-sided Copper

Board type	Epoxy glass	SRBP
Double sided copper	BS4584 part 16	BS4584 part 5
Max. working temp.	155°C	97°C
Nom. board thickness (inc copper)	1,6mm	
Copper thickness	35µm or 1oz/ft ² or 305g/m ²	

Board specifications: Plated Through Hole Boards

Board type	Epoxy glass
PTH	BS 4584 EP-GC-Cu 3 FR4
Max. working temp.	155°C
Nom. board thickness	1,6mm
Laminate copper thickness	35mm or 1oz/ft ² or 305g/m ²
Plated copper	25µm
Tin lead	10µm
Total	70µm

Note: bare boards are UL V-0 recognised components file number E116551.

Bare boards are approved to BS 9762

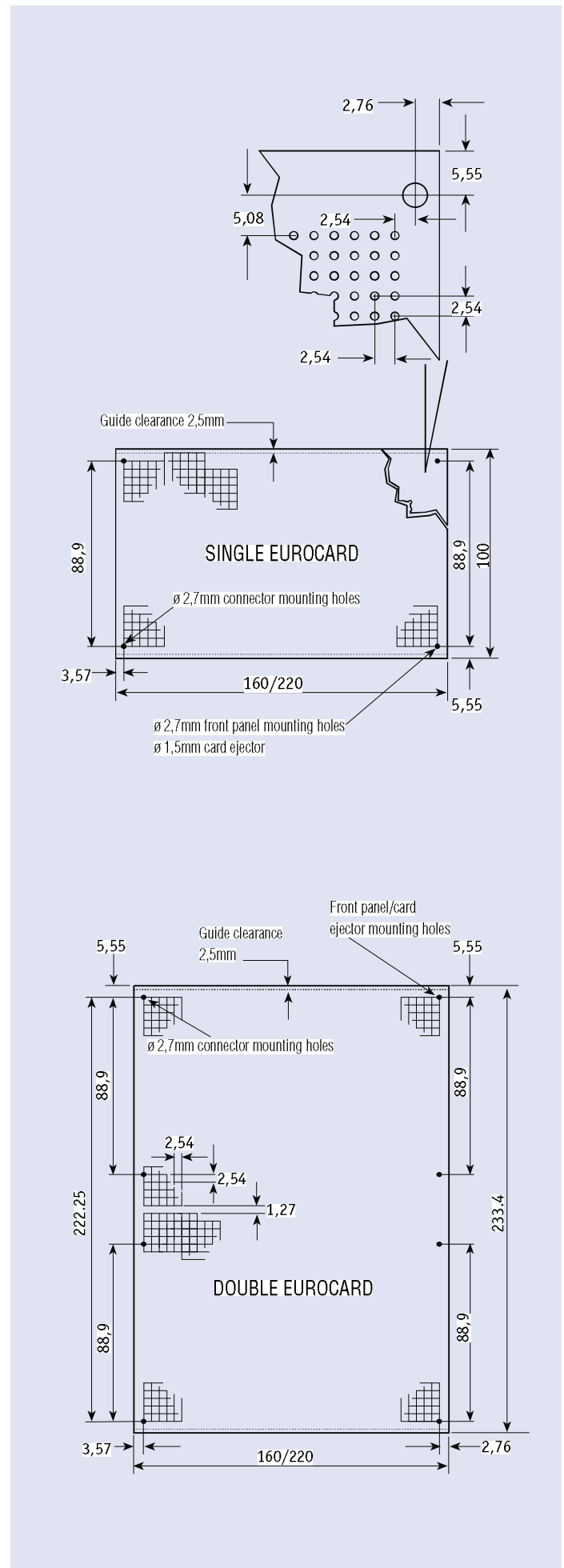

Prototyping boards

PTH Microboard

Features

- Reliability of plated through holes
- DIN 41494 cardframe compatible
- Medium packing density
- DIN 41612 connector position, up to 96/96 ways, front and rear
- Solder resist protection to component side of board
- Two Vcc power rails and a 0V ground plane
- Grid print to aid component layout
- Microbus backplane compatible

Application

Specifically designed for microprocessor applications where high reliability, freedom from crosstalk and interface capability is a requirement. Fully compatible with DIN 41494 cardframes and equally suited to soldered or wirewrapped interconnections. When soldering a PTH board, capillary action draws the solder around the component leads forming extremely solid, reliable joints, particularly important in high vibration applications.

Screening

A maximum copper colander 0V ground plane is provided on the component side of the board. It is recommended that this side is used for interwiring with looms lying flat on the ground plane surface. This will reduce crosstalk from signal lines coupling directly to the ground plane.

PTH Microboard			Ordering information
Board dimensions	7,62 pitch IC DIP rows/pads	15,24 pitch IC DIP rows/pads	Order code
100 x 160	4/44	4/44	222-2991
100 x 220	4/67	4/67	222-2992
233,4 x 160	11/44	17/44	222-2993
233,4 x 220	11/67	17/67	222-2994

PTH Square pad boards

By having plated through holes, these boards are able to offer the same high density and flexibility as the square pad Eurocards but for hard wiring applications. A high level of interfacing may be achieved with boards able to accept 96/96 way DIN 41612 connectors.

Power rails are provided along the length of the board and a colander ground plane affords maximum screening to the component side of the board.

Features

- Maximum packing density
- Total flexibility using hard wire or wirewrapping techniques
- DIN 41494 cardframe compatible
- DIN 41612 connector pattern up to 96/96 ways, front and rear
- Solder resist protection to component side of board

PTH Square pad boards				Ordering information
Board dimensions	No. of Pads		Base material	Order code
	width	length		
100 x 160	32	48	Epoxy glass	222-26492
100 x 220	32	71	Epoxy glass	222-53134
233,4 x 160	70	48	Epoxy glass	222-53135
233,4 x 220	70	71	Epoxy glass	222-53136

Note: Hole grid 2,54 x 2,54mm hole dia. 1,02mm

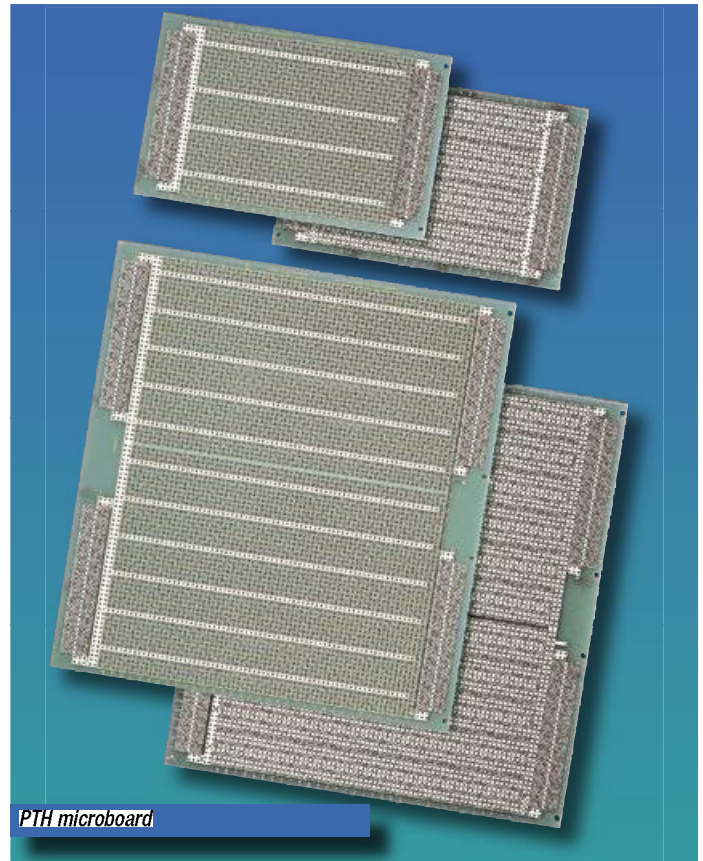

PTH microboard

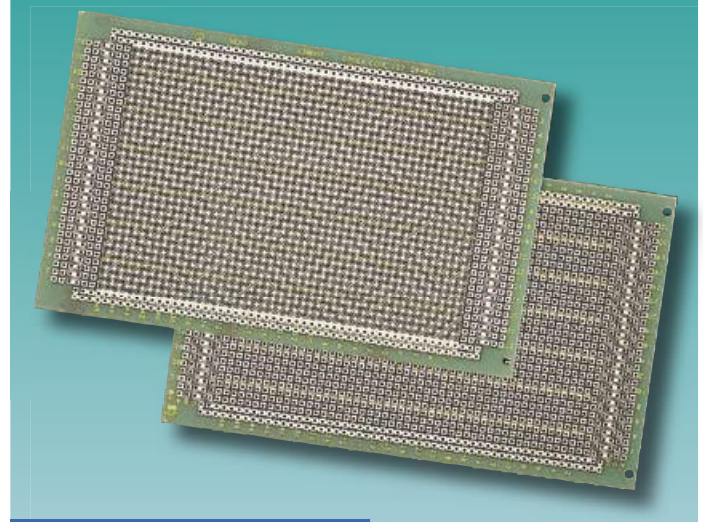

PTH Square Pad Board

Prototyping boards

Microboard – Double- and Single-sided

Features

- DIN 41494 cardframe compatible
- Medium packing density
- DIN 41612 connector up to 64/96 ways, front and rear
- Solder resist protection to component side of board
- Grid print to aid component layout
- Microbus backplane compatible
- 0V ground plane screen

Microboard – Double sided

The forerunner of the PTH microboard, this range of boards finds similar applications in all but high reliability of plated through holes and restricted use of DIN 41612 connectors up to 64/96 ways only.

Double-sided Microboard			Ordering information
Board dimensions	7,62 pitch IC DIP rows/pads	15,24 pitch IC DIP rows/pads	Order code
100 x 160	4/46	4/46	10-2845
233,4 x 220	11/69	7/69	10-2858

Microboard – Single sided with grid print

This low cost Eurocard has no 0V ground plane on the component side, but is otherwise identical to the double sided microboards.

Single-sided Microboard			Ordering Information
Board dimensions	7,62 pitch IC DIP rows/pads	15,24 pitch IC DIP rows/pads	Order code
100 x 160	4/46	4/46	10-27563

*Note: Hole grid 2,54 x 2,54mm Hole dia. 1,02mm
N.B. 3,81mm centre gap on double height boards*

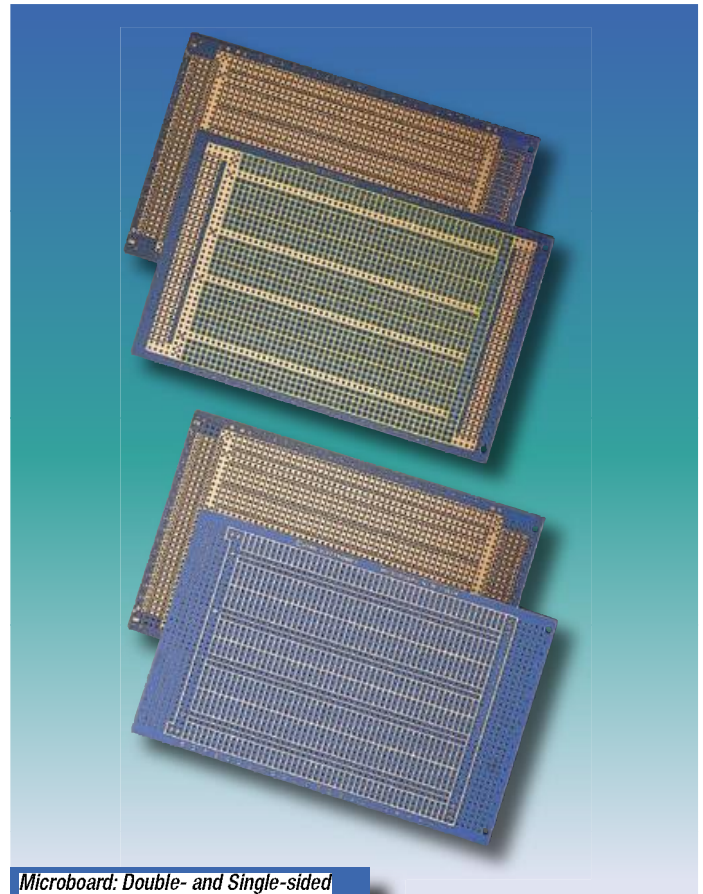

Prototyping boards

3 Plane high density DIP board

Ideal for high density circuitry using wirewrapping, hardwiring or Verowire interconnection techniques. The board features two power rail options, either as two 0V or one Vcc and a ground plane on the component side. Power rails run between rows of 7,62 pitch integrated circuits allowing end-to-end stacking for increased packing density.

Features

- High packing density
- Two Vcc and one 0V power rail options
- DIN 41494 cardframe compatible
- DIN 41612 connector pattern, up to 64/96 ways
- Microbus backplane compatible

Backplane compatible

By utilising a simple track break facility to isolate Vcc from pin 32, high density DIP boards are fully compatible with the Vero Technologies Microbus backplane range.

3 Plane high density DIP board			Ordering information
Board dimensions	7,61 pitch IC DIP rows/pads	15,24 pitch IC DIP rows/pads	Order code
100 x 160	5/53	4/53	10-0581

Notes: hole grid 2,54 x 2,54mm Hole dia. 1,02mm; 3,81mm gap on double height boards

DIN 41494 Compatible DIP Board

A low density board designed for hard wiring of integrated circuits. 0V and Vcc rail patterns are duplicated on the component side of the board giving increased power distribution. Connector pattern at rear edge of board allows input/output via ribbon cable headers.

Features

- DIN 41494 cardframe compatible
- DIN 41612 connector position, up to 64/96 ways
- Rear end input/output facility
- Microbus backplane compatible, with a grid print to aid component layout
- Ample room for wiring looms and/or discrete components

Note: The board pattern is turned through 90° on double height Eurocard versions in order to maximise packing density.

DIN 41494 Compatible DIP Board				Ordering information
Board dimensions	7,62 pitch IC DIP rows/pads	15,24 pitch IC DIP rows/pads	Base material	Order code
100 x 160	4/32	3/32	Epoxy	10-2446

Note: hole grid 2,54 x 2,54mm Hole dia. 1,02mm

DIN 41494 Eurocard: Veroboard Pattern

A unique board giving the advantages of Veroboard with the flexibility of Eurocard and DIN 41612 connectors. Primarily used for hard wiring of discrete components, typically in analogue circuits, it is equally useful where a number of common bus or signal lines are required. For wirewrapping applications a 3,81mm gap on the double height boards maintains board patterns on grid with adjacent connectors.

Features

- DIN 41494 cardframe compatible
- Ideal for hard wiring of discrete components; grid pattern to aid component layout
- Microbus backplane compatible, and available in Eurocard sizes

DIN 41494 Eurocard, Veroboard Pattern				Ordering information
Board dimensions	Tracks	Holes per track	Base material	Order code
100 x 160	34	52	Epoxy	10-2449
100 x 220	34	77	Epoxy	10-27558

Notes: Hole grid 2,54 x 2,54mm Hole dia. 1,02mm; 3,81mm gap on double height versions

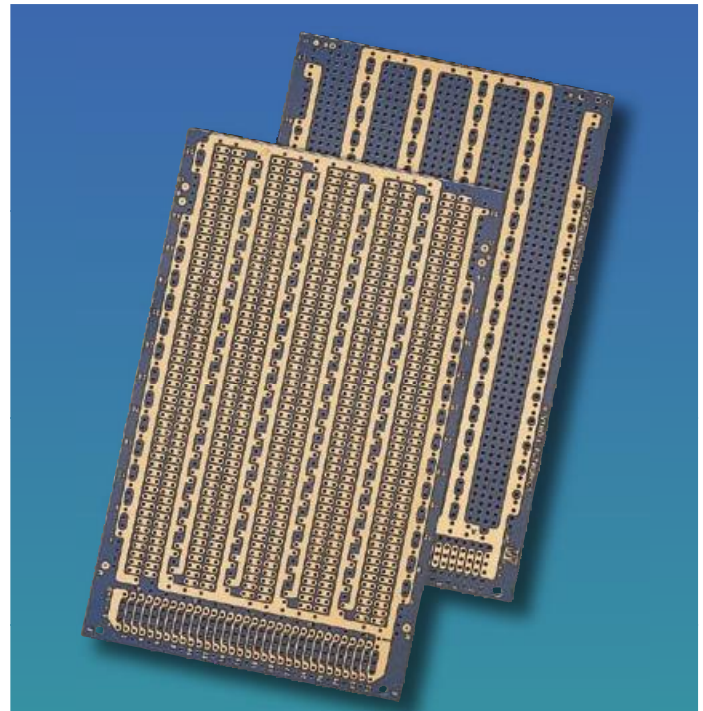

3 Plane High-density DIP board

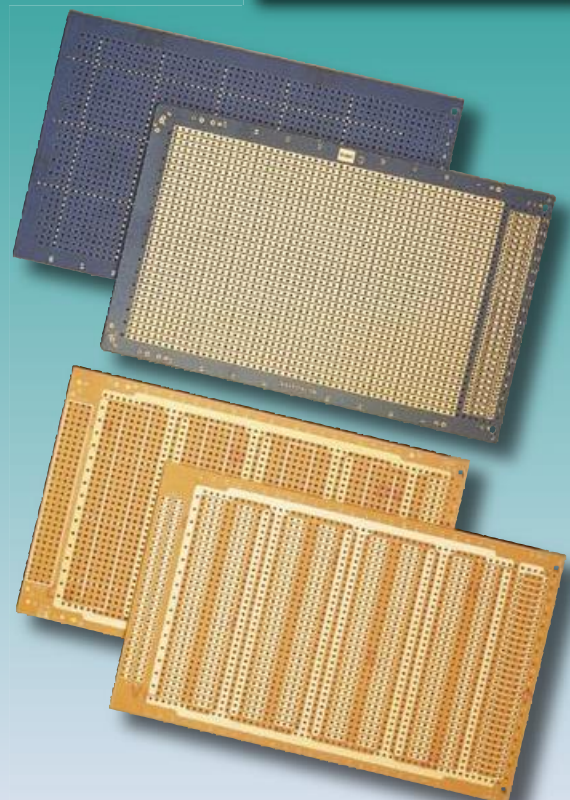
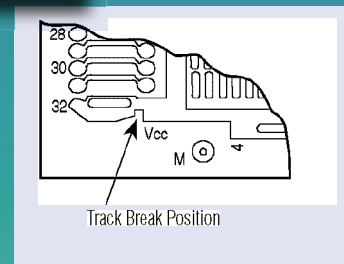

DIN 41494 Compatible DIP Board and Veroboard pattern Eurocard

Prototyping boards

Veroboard pattern with colander ground plane

Similar in use to the standard Veroboard pattern but offering the advantages of full 0V colander ground plane to provide maximum screening on the component side of the board.

Features

- DIN 41494 cardframe compatible and DIN 41612 connector pattern up to 96/96 ways
- Ideal for hard wiring of discrete components
- Colander ground plane for maximum screening
- Microbus backplane compatible

Veroboard pattern, with colander ground plane Ordering information

Board dims.	Tracks	Holes/tracks	Base material	Order code
100 x 160	34	54	Epoxy glass	03-2990

Note: Hole grid 2,54 x 2,54mm, hole dia. 1,02mm and 3,81mm gap on double height boards

Square pad board

A range of boards offering total flexibility and maximum density of wirewrapped circuitry. Any size of wirewrapping DIP socket or terminal pin can be accepted in either X or Y planes. Vcc and 0V rails may be daisy chained from post to post around the board eliminating the need to stake pins in power rails as on other types of board.

Features

- Maximum packing density
- Total flexibility using hard wire or wirewrapping techniques
- DIN 41494 cardframe compatible and DIN 41612 connector pattern up to 96/96 ways
- Grid references to both sides of board to aid component layout and to assist wiring
- Microbus backplane compatible

Note: Component grids compatible with connectors. Board 03-0111L has a full board pattern aligned with the lower connector giving a 1,27mm offset between the top and bottom connector patterns.

Square pad board Ordering information

Board dimensions	No. of Pads		Base material	Order code
	width	length		
100 x 160	34	54	Epoxy glass	03-0026
100 x 220	34	77	Epoxy glass	03-27555
233,4 x 160	85	52	Epoxy glass	03-0111
233,4 x 160	86	52	Epoxy glass	03-27556*
233,4 x 220	86	75	Epoxy glass	03-27557*

*Note: Hole grid 2,54 x 2,54mm Hole dia. 1,02mm *3,81mm gap on these boards*

Square pad board with colander ground plane

A single height Eurocard similar to the standard square pad board but offering the additional advantage of 0V colander ground plane.

Features

- Maximum packing density
- Total flexibility using hard wire or wire wrapping techniques
- Colander ground plane for maximum screening
- DIN 41494 cardframe compatible and DIN 41612 connector pattern up to 96/96 ways
- Grid references to both sides of board to aid component layout and to assist wiring
- Microbus backplane compatible

Square pad board with colander ground plane Ordering information

Board dimensions	No. of Pads		Base material	Order code
	width	length		
100 x 160	34	54	Epoxy glass	03-2989

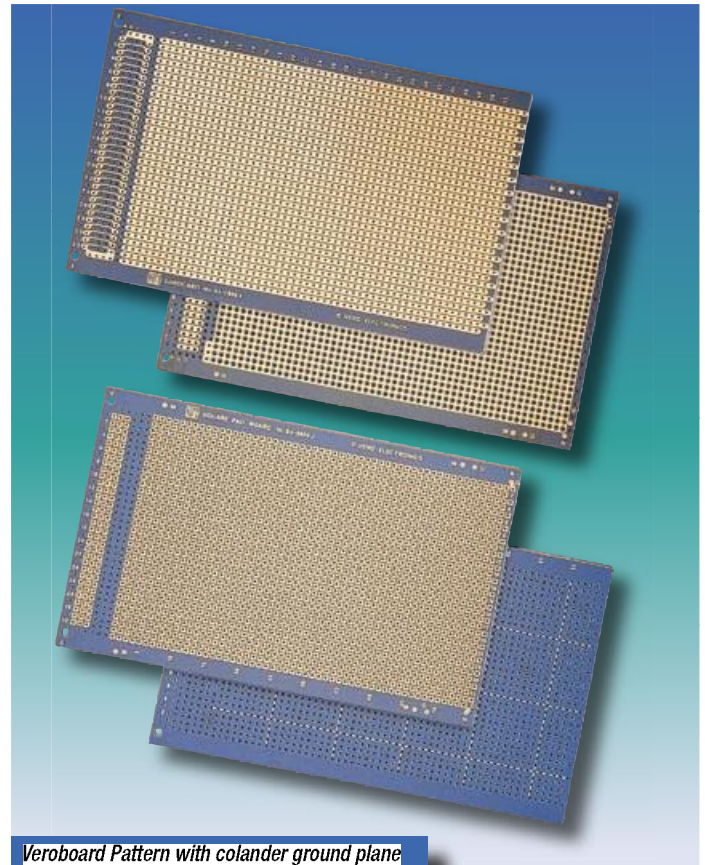

Veroboard Pattern with colander ground plane

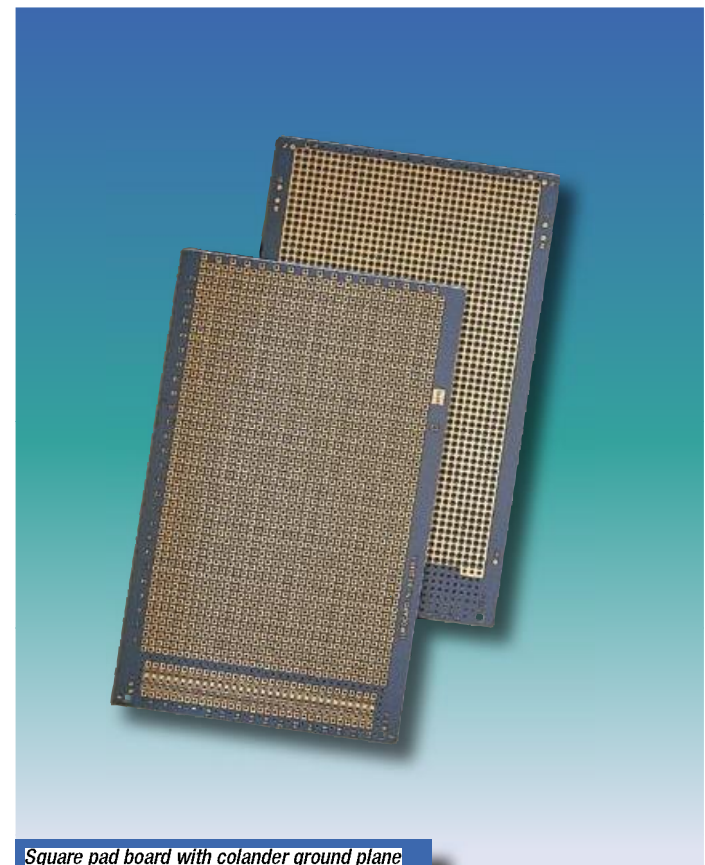

Square pad board with colander ground plane

Prototyping boards

Budget Eurocard

A range of low cost prototyping boards primarily for hard wiring of general discrete components, as used in analogue and general circuitry, but equally useful where a number of common bus or signal lines are required.

Features

- Ideal for low cost prototyping
- DIN 41494 cardframe compatible
- Fixing holes provided for DIN 41612 connector
- Microbus backplane compatible

Budget Eurocard			Ordering information
Board dims.	No. of tracks	Hole per track	Order code
100 x 160	36	60	09-2196
100 x 220	36	83	09-27562

Note: hole grid 2,54 x 2,54mm Hole dia. 1,02mm

DIP Boards

A low density board designed for hard wiring of integrated circuits. Ample room is provided between rows for wiring looms and discrete components. 0V and Vcc rail patterns duplicated on the component side of the board give increased power distribution.

Features

- Ideal for hard wiring applications
- DIN 41612 or DIN 41617 connector patterns
- Grid print to aid component layout
- Microbus backplane compatible

Note: The board pattern is turned through 90° on double Eurocard versions in order to maximise packaging density.

DIP Board			Ordering information	
Board Dimensions	7,62 pitch IC DIP rows/pads	15,24 pitch IC DIP rows/pads	Base material	Order code
100 x 160	4/32	3/32	SRBP	10-1041
100 x 160	4/32	3/32	Epoxy	10-1042
233,4 x 160	7/47	6/47	Epoxy	10-3183

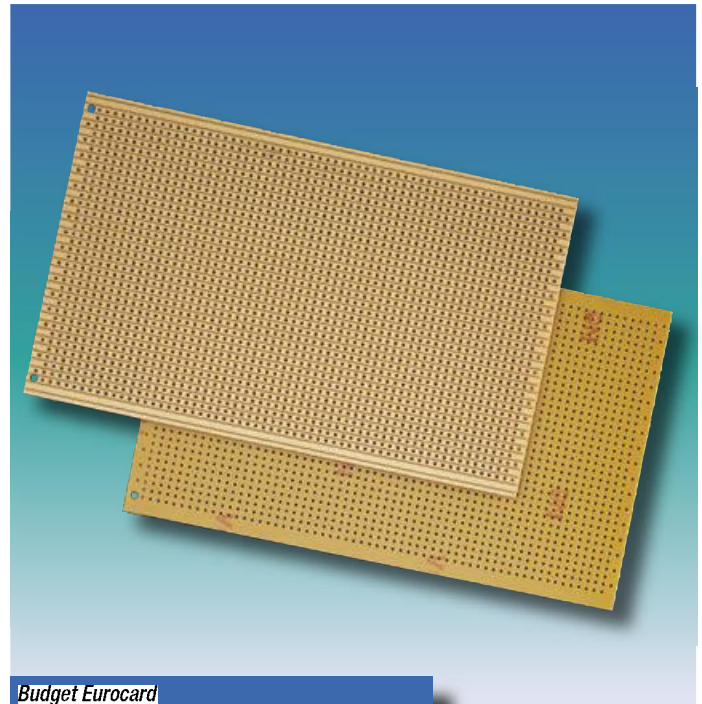

Budget Eurocard

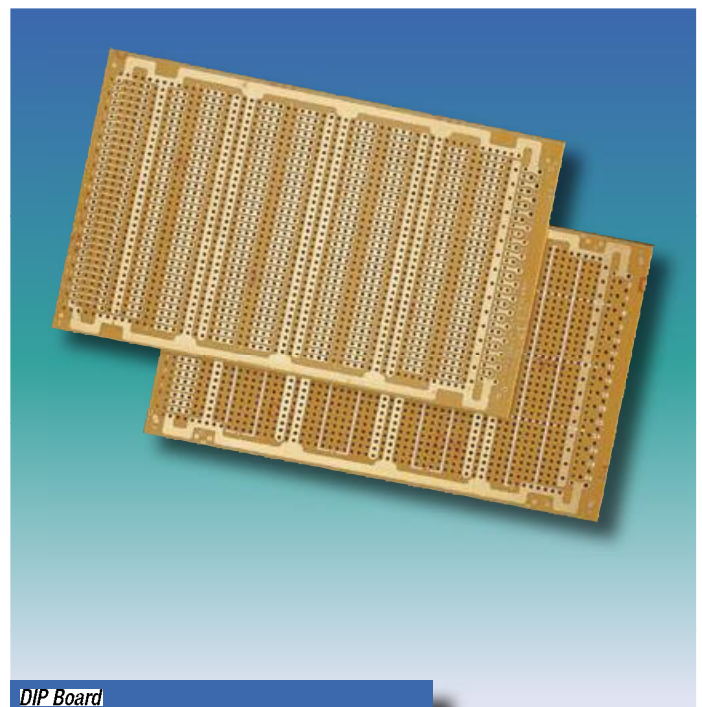

DIP Board

Prototyping boards

Plug-in Veroboard

This board combines the unique Veroboard pattern with the 37 way 2,54mm pitch direct edge connector. Intended primarily for hard wiring of discrete components it is equally useful where a number of common bus or signal lines are required.

Features

- Ideal for hard wired applications
- 37 way 2,54mm pitch gold plated tongue

Board specifications

Board type	Epoxy glass
Base material	SRBP
Single sided copper	BS4584 part 16
Max. working temp.	155°C
Nom. board thickness (inc. copper)	1,6mm
Copper thickness	35µm or 1oz/ft ² or 305g/m ²

Plug-in Veroboard		Ordering information			
Dimensions	Tracks	Holes per track	Base material	Order code	
100 x 160	37	57	SRBP	09-1036	

Note: hole grid 2,54 x 2,54mm Hole dia. 1,02mm Contact pitch 2,54mm

DIP Plug-in board – for single and double sided connectors

This range of DIP boards is provided with either single or double sided contacts for interfacing via direct, edge card connectors. Primarily low density, they have been designed for hard wiring of integrated circuits. A test point facility is given by copper pads situated at the front end of each board.

Features

- Ideal for hard wiring applications
- Single or double sided contacts
- Profiled or full width gold plated tongue
- Choice of contact pitch and number of ways
- Grid pattern to aid component layout
- Test point facility

Board specification

Board type	Epoxy glass
Double sided copper	BS4584 part 16
Max. working temp.	155°C
Nom. board thickness (inc. copper)	1,6mm
Copper thickness	35µm or 1oz/ft ² or 305g/m ²

DIP Plug-in board for single and double sided connectors			Ordering information	
Board dimensions	7,62/15,24 pitch ICs rows/pads	Tongue no. of ways	Base material	Order code
114,3 x 165,1	4/39	22/22	Epoxy	06-0147

Note: Hole grid 2,54 x 2,54mm Hole dia. 1,02mm

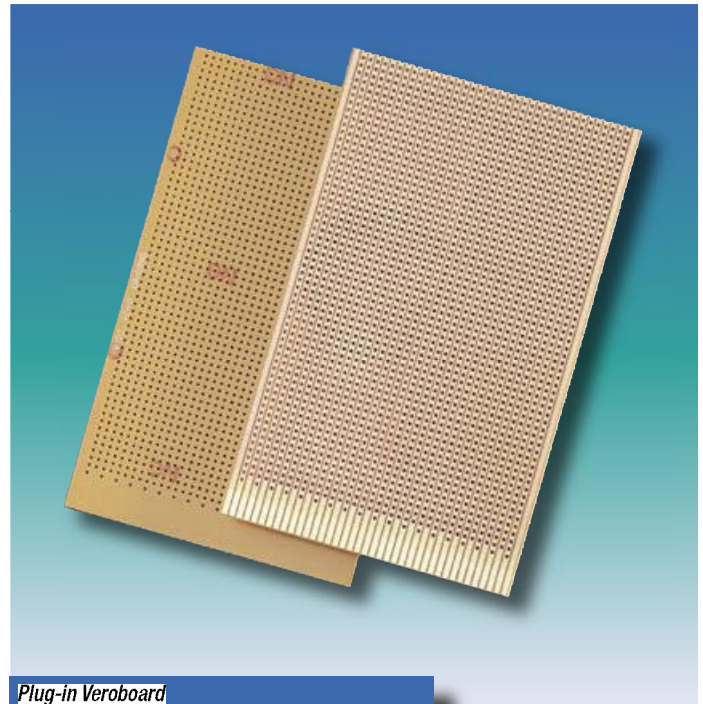

Plug-in Veroboard

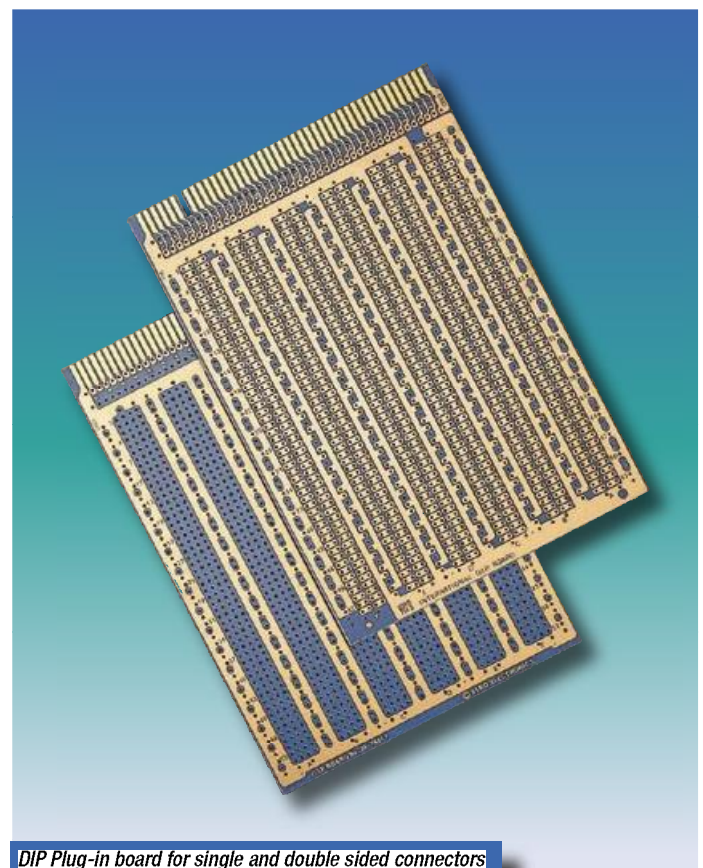

DIP Plug-in board for single and double sided connectors

Prototyping boards

Veroboard – Metric pitch

A range of general purpose Eurocards primarily for hard wiring of discrete components, typically in analogue circuits, they are equally useful where a number of common bus or signal lines are required. The boards feature a metric pitch of 2,50 x 2,50mm or 5,0 x 2,50mm which is not DIN 41612 compatible, but can be used inside modules.

Features

- Metric pitch
- Ideal for hard wiring of discrete components
- All pins shown on pages X – Y are compatible with this board

Veroboard, metric pitch				Ordering information	
Board dims.	Tracks	Holes/track	Board pitch	Base material	Ordercode
100 x 160	39	64	2,5 x 2,5	SRBP	09-1034
100 x 160	39	64	2,5 x 2,5	Epoxy	09-1461

Note: hole dia. 1,02mm

Plain Boards – Metric and Imperial Pitch

These boards offer total flexibility for the hard wiring of discrete components or the mounting of wirewrap sockets and pins and for the prototyping of analogue circuitry.

Features: Metric pitch

- Ideal for hard wiring of discrete components
- For use with solder pins
- Total flexibility
- Compatible with DIN 41494 cardframes

Features: Imperial pitch

- Compatible with DIN 41494 cardframes
- Fibreglass material
- For use with solder pins or wirewrap DIP sockets
- DIN 41612 connector compatible
- Grid printed for component reference

Plain boards - metric and imperial pitch				Ordering information	
Board dimensions	Rows of holes	Hole matrix	Base material	Order code	
100 x 160	34 x 64	2,5 x 2,5	SRBP	09-1040	
100 x 160	39 x 60	2,54 x 2,54	Epoxy	09-19082	

Note: hole dia. 1,02mm

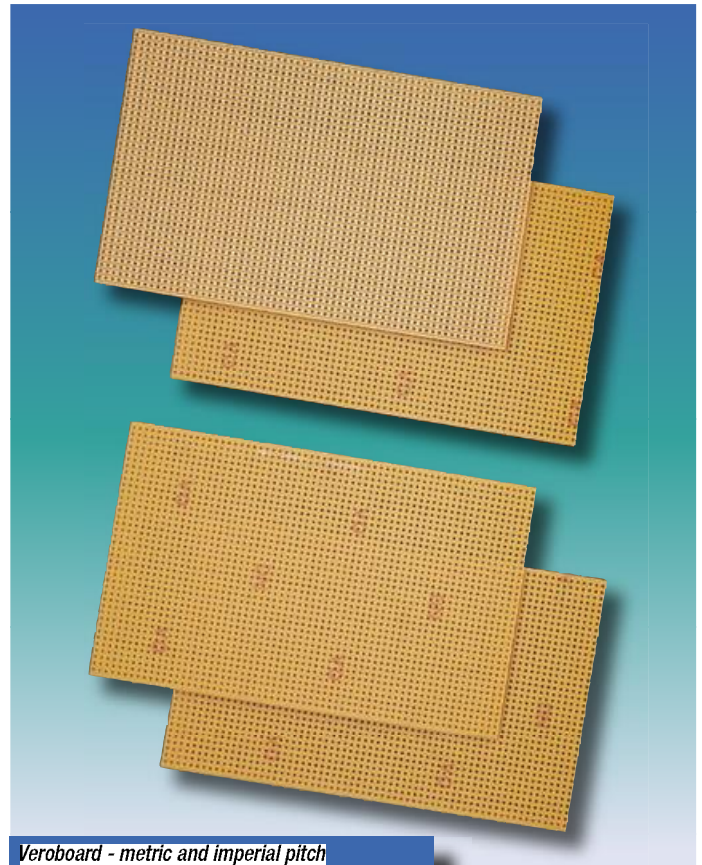

Veroboard - metric and imperial pitch

Non-Eurocard Prototyping Boards

Veroboard – Single sided copper

Ideal for development and prototyping work, Veroboard is designed primarily for hard wiring of discrete components, typically in analogue circuits, but is equally useful where a number of common bus or signal lines are required.

Veroboard is manufactured from copper clad laminated board which has been pierced with a grid of holes and machined to provide parallel tracks.

Features

- Ideal for hard wiring or discrete components
- Range of standard sizes
- Choice of hole sizes and grid pitch

Veroboard – single sided copper

Ordering information

Board dimensions	No. of pierced copper tracks	Holes/track	Base material	Order code
121,92 x 101,60	41	44	SRBP	01-0021
100,84 x 162,56	28	64	SRBP	07-0008
111,76 x 176,53	40	61	SRBP	01-0014
204,75 x 393,70	78	155	SRBP	67-1902
95,10 x 454,66	34	179	Epoxy	01-0112
95,10 x 454,66	34	179	SRBP	01-0040
119,38 x 454,66	36	179	SRBP	01-0041
119,38 x 454,66	38	179	SRBP	01-0043
179,07 x 454,66	60	179	SRBP	01-0042
100,00 x 500,00	36	197	SRBP	01-27567
100,00 x 500,00	36	197	Epoxy	01-27568

Note: hole grid 2,54 x 2,54mm Hole dia. 1,02mm

Verostrip – Single sided copper

A variant of Veroboard designed to provide a simple and inexpensive mounting board for discrete components or integrated circuits. The board is suitable for all applications where a conventional tag strip or group board might be used.

Features

- Ideal for hard wiring of discrete components
- Central track break already provided

Verostrip, single sided copper

Ordering information

Board dimensions	No. of pierced copper tracks	Holes/track	Base material	Order code
38,1 x 214,6	81	15	SRBP	01-0171

Note: Hole grid 2,54 x 2,54mm Hole dia. 1,02mm

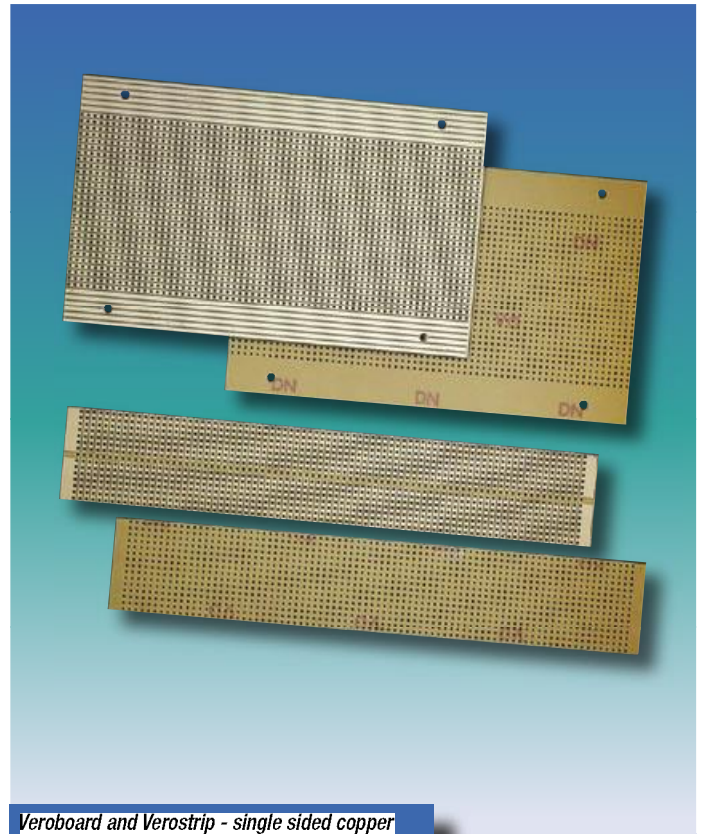

Non-Eurocard Prototyping Boards

Plain Board

A fully pierced board designed for prototyping analogue circuitry. Utilising Vero Technologies terminal pins, this board offers total flexibility for hard wiring of discrete components or wirewrapping sockets or pins.

Features

- Ideal for hard wiring of discrete components
- Total flexibility
- May also be used for wirewrapping

Plain board			Ordering information	
Board dimensions	No. of holes		Base material	Order code
	width	Length		
95,10 x 454,66	34	179	SRBP	02-0134

Note: hole grid 2,54 x 2,54mm Hole dia. 1,02mm

DIP Breadboard

A range of low density boards for hard wiring of integrated circuits, particularly useful in R & D applications. 0V and Vcc rail patterns are duplicated on the component side of the board giving increased power capacity. These boards do not have gold plated contacts, therefore offering a cost saving over plug-in boards. In place of contacts, individual mounting pads for terminal pins are provided.

Features

- Ideal for hard wired applications
- Grid print to aid component layout
- Full range of terminal pins available for interfacing

DIP Breadboard			Ordering information	
Board dims	Rows/Pads	Rows/Pads	Base material	Order code
114,30 x 156,21	4/39	4/39	SRBP	06-0166
203,30 x 194,31	5/76	5/76	SRBP	06-0168

Notes: 7,62 pitch IC DIP 15,24 pitch IC DIP; hole grid 2,54 x 2,54mm hole dia. 1,02mm

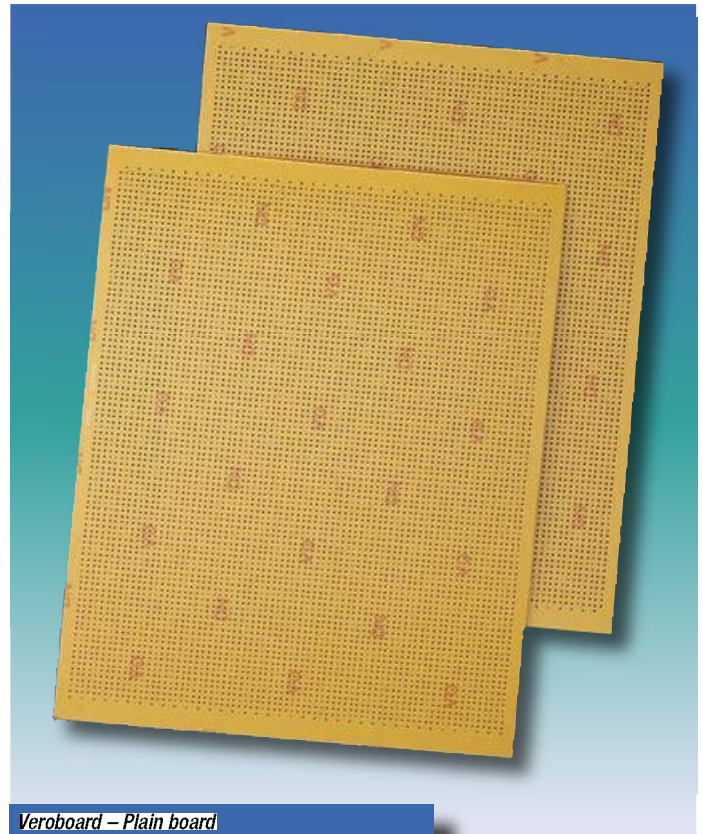

Veroboard – Plain board

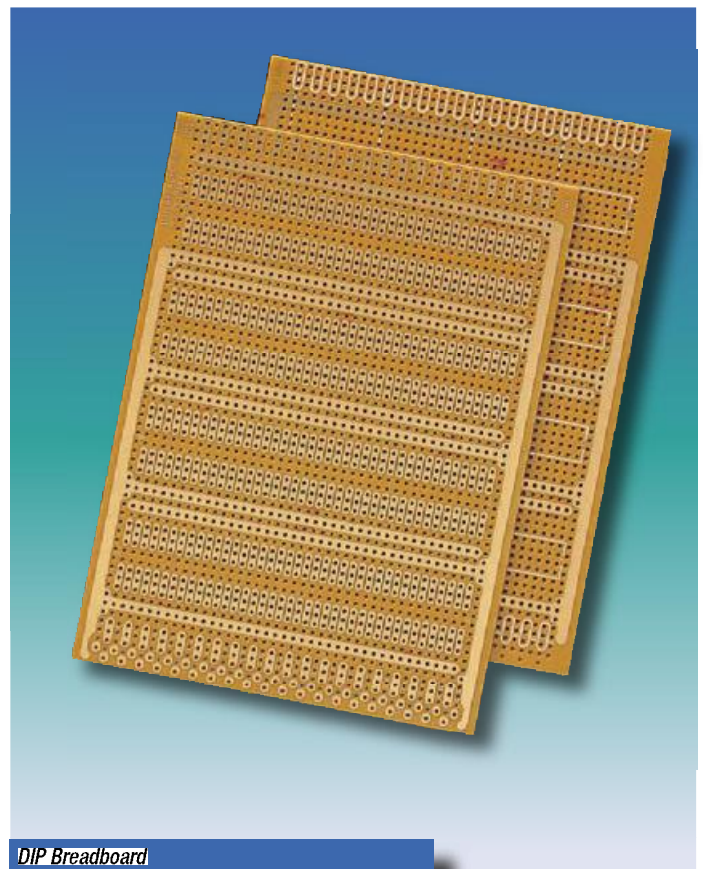

DIP Breadboard

Eurocard Extender Boards

Double sided exender boards

A range of double sided extender boards to enable testing of single and double height Eurocards, both 160 and 220mm deep, using DIN 41612 type B and C connectors. The extender board plugs directly into a subrack connector with the unique support/ejector mechanism at the front supporting the board under test. Terminal assemblies (supplied with the boards), may be fitted to the board to allow easy attachment of scope probes typically for measuring voltage levels.

Note: This feature is not available on the 96/96 way extenders.

Features

- Eurocard compatible
- Suitable for 160 and 220mm deep boards
- DIN 41612 type B and C connectors
- Support/ejector mechanism
- Terminal assemblies for ease of testing (except 96/96 way versions)
- Solder resist coating to prevent solder bridging and prevent finger staining

Contents of kit

Description	Qty
Board (assembled with connectors)	1
Support/eject mechanisms	2
Terminal assemblies (where applicable)	

Double Height Extender Boards				Ordering information
For frame height	Connectors fitted		Type	Order code
	Plug	Socket		
3U	1 off	1 off	64/64	09-3817
6U	2 off	2 off	64/64	09-0106
3U	1 off	1 off	64/96	09-3865
6U	2 off	2 off	64/96	09-0108
3U	1 off	1 off	96/96	09-2459
6U	2 off	2 off	96/96	09-2460

Note: hole grid 2,54 x 2,54mm hole dia. 0,9mm Note: 3,81mm gap on double height boards

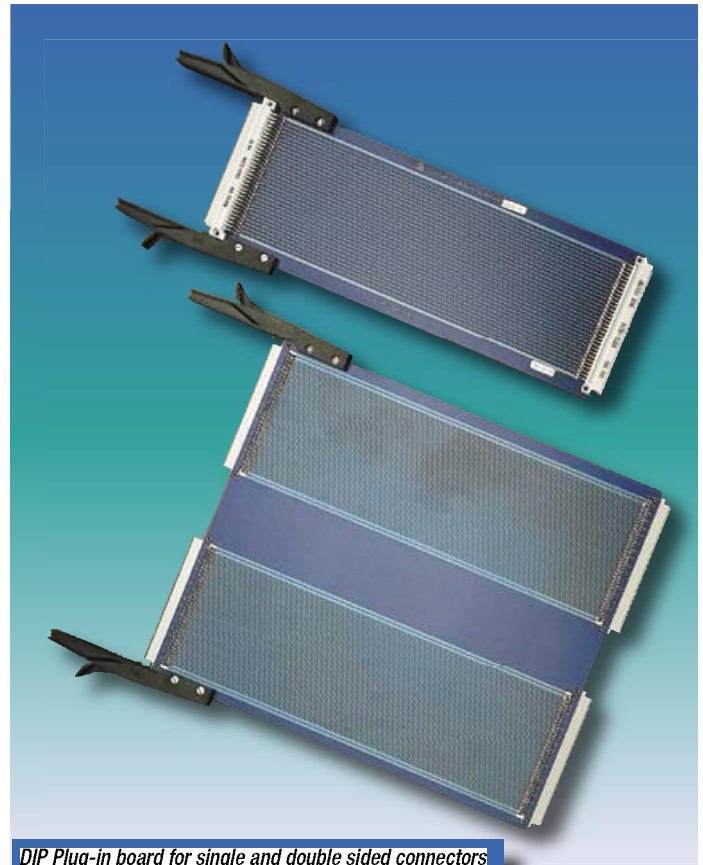

DIP Plug-in board for single and double sided connectors

Eurocard extender boards

Multilayer extenders

This multilayer extender board offers the engineer the best possible guarantee against crosstalk due to the 0V guarding being positioned on three sides of each individual signal line.

The multilayer construction features a control 0V ground plane inner layer with a latticed trace around all jumper pin positions for maximum shielding. The extender board features 42 signal lines on both sides of the board which are protected by an 0V guard track between each pair of signal lines. The guard track is connected to the 0V inner layer plane at both ends by the use of via holes.

The power rails on the outer edges of the board feature a cross patching facility which uses jumper links in order to give the user complete flexibility when trying to match a particular backplane system. The board is supplied completely assembled with connectors at both ends.

Power rails are committed to pins 1abc, 2abc, 31abc and 32abc. If necessary any of these power rails may be connected to the 0V inner plane by use of cross patching jumper links.

Features

- 3 layer bonded multilayer construction with a 0V ground plane sandwich between layers
- Patented 0V guard tracking between all signal lines
- Flexible power rail construction with up to four separate Vcc rails and a 0V return plane
- Voltage and current measuring facilities are available by use of wirewrapping pins and jumper links which are fully assembled to the board
- Logic analyser or backplane stub terminator position on board
- Expandable to 3U, 6U, 9U etc. in many combinations using the compatible range of PTH and super PTH extender boards
- Suitable for 160 and 220mm deep systems
- Compatible with multilayer Microbus backplanes and PTH backplanes
- Support/eject mechanism to ensure that the daughter board remains captive within the guides when ejecting and that the correct connector breaks when dismantling

Multilayer Extenders	Ordering information
Description	Order code
96/96 multilayer extender board	38-39084
Extender board conversion kit	188-27542

Board specification

Board type	Epoxy glass
Plated through hole	BS4584 part 16
Copper thickness to outer layers	38µm
Plated copper	37µm
Tin lead	5µm
Total	80µm
Copper thickness inner layers	38µm

Note: bare boards are UL 94 V-0 recognised components file number E116551. Bare boards are approved to BS9762.



Multilayer Extender boards

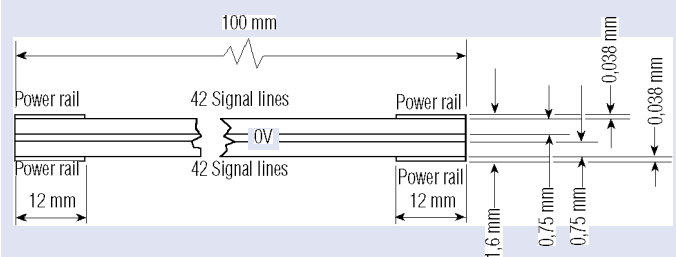

Characteristics impedance

The separation of signal layers to the 0V ground plane is 0,74mm and the signal track width is 0,3mm which gives a theoretical characteristic impedance of 94Ω with a Z_0 tolerance of ±5%.

Note: $Z_0 = 94\Omega \pm 5\%$ excluding all holes in the boards

$Z_0 =$ approximately 80Ω including connector and jumper pin holes

$Z_0 =$ approximately 65Ω when active daughter board is in position.

Note: The guard tracking arrangement is manufactured under licence from University College, London.

Eurocard extender boards

Multilayer uncommitted extender boards

These extender boards have been designed to offer the greatest flexibility in the arrangement of power, ground and signal lines, yet afford the engineer the best possible protection against crosstalk by the use of a patented method of 0V guard tracking. The 96 signal lines are positioned over three layers with the facility to commit any line to any voltage. The remaining layers are committed to 0V and Vcc planes, thus minimising voltage drop over the length of the extender. These extenders are supplied completely assembled with connectors at each end plus wirewrap pins, jumpers and a reverse DIN connector for the fitment of a "stub" terminator or a logic analyser.

Signal lines can be committed to either 0V or Vcc by using the Commitment strap shown below. By fitting the tag into the holes in the guard track (round pads) adjacent, the connector pattern will commit the required pins to 0V. Conversely, rotating the strap 180o and fitting the tag to the square padded holes will commit to Vcc. This process is to be repeated at both ends of the extender.

Features

- 6 layer construction providing full voltage and ground planes
- Patented 0V guard tracking between all signal lines
- Full 0V and Vcc planes plus two auxiliary Vcc rails
- Suitable for 220 and 280mm deep subtracks
- Total flexibility of voltage and ground committment
- Signal line interrupt facilities by means of wirewrap pins and jumper links which are pre-fitted to the board
- Reverse 96/96 DIN connector to accept stub terminator or logic analyser
- Support/eject mechanism to ensure that the correct connector breaks when dismantling and that the daughter board remains captive within the guides when ejecting
- Expandable in height by multiples of 3U. This is achieved by means of an extender board conversion kit

Board specification

Dielectric	Epoxy glass BS4584 EP-GC-Cu3 FR4
Nom. thickness	1,6mm
Base copper thickness	35µm
Finish	
Plated copper	25µm average
Tin lead	5µm nominal
Total	68µm outer layers only

Note: bare boards are UL 94 V-0 recognised components file number E116551. Bare boards are approved to BS9762. The guard tracking arrangement is manufactured under licence from University College, London.

Multilayer Uncommitted Extender Board	Ordering information
Description	Order code
220mm deep Un-committed extender	38-63623
280mm deep Un-committed extender	38-61486

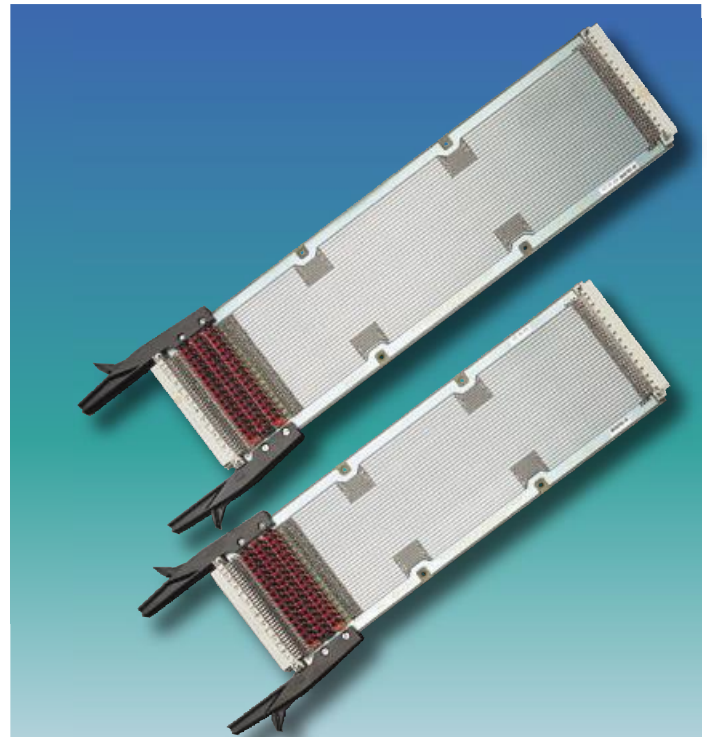

Multilayer uncommitted extender boards

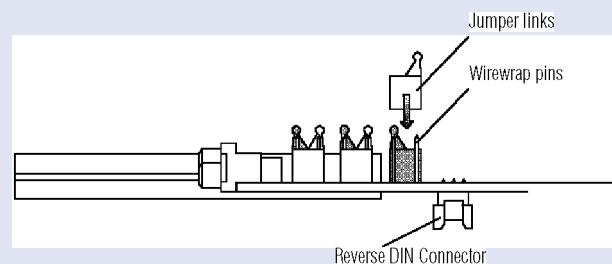
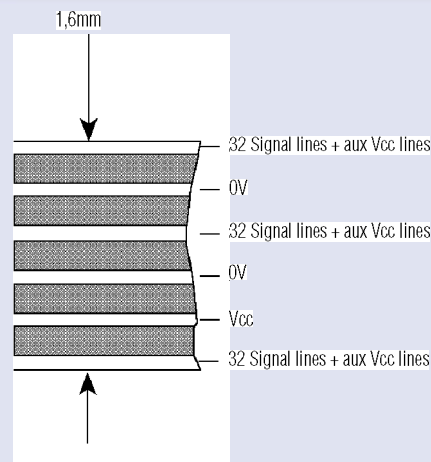

Eurocard bus systems

Microbus backplanes

Features

- PTH Eurocard backplanes designed for use with microprocessors
- Reliability of plated through holes
- Minimal crosstalk
- DIN 41612 connectors
- DIN 41494 cardframe compatible
- Choice of connector styles and pitches:
3HP (15,24mm) for PCB's for hard wired daughter boards.
4HP (20,32mm) for two level wirewrap daughter boards

96/96 Way Version

Ideal for high speed applications using 96/96 way connectors, screening is provided on row b between each signal track on the backplane and, via the connector, through onto the individual cards. Alternatively for slower applications the 96/96 way connector allows the use of a maximum of 84 separate signal lines by simply breaking the 0V commoning line in the end position. Using either of these methods input/output connections are generally made at the front end of the individual plug-in boards. If a 64/96 way connector is used on the system, the 0V screen is still a feature of the Microbus, with the added advantage of input/output connections being possible from the rear of the system.

When using 0V and two power rails, pin 1 and 32 on rows a, b and c are fully committed to 0V and commoned together at one end. Two separate Vcc planes are provided for dual voltage systems and are committed to pins 2 and 31 on rows a, b and c. If 0V and three power rails are required the same situation exists as for two power rails except that it is now necessary to convert 0V on pins 32 a, b and c to Vcc by simply cutting the 0V link on the extreme edge of the connector side of the backplane. Power onto the 0V and Vcc planes is made via plated through holes positioned beneath the connector fixing screws.

64/96 Way version

A low cost version of the Microbus backplane still with the reliability of plated through holes but restricted in use to only 64/96 way connectors. The basic design is very simple, with pin 1 and 32 on rows a and c committed to 0V with a complete 0V screen over one side of the board. Pin 2 and 31 on rows a and c are committed to Vcc. This leaves 56 separate signal lines from pin 3 a and c to pin 29 a and c inclusive.

Crosstalk

Tests have been carried out on the 84HP version by feeding a 1MHz square wave signal (5ns rise and fall times), through a DIN 41612 connector and measuring the adjacent tracks at the opposite end.

Note: The Microbus motherboard was not terminated, which would have reduced the amplitude to the crosstalk and changed its shape considerably.

Microbus Backplanes				Ordering information
Conn. type	Conn. pitch (HP)	Size/Slots	Length	Order code
96/96	15,24 (3HP)	84HP/28	426,3 mm	222-2470
96/96	20,32 (4HP)			222-22847
64/96	15,24 (3HP)			222-26025
64/96	20,32 (4HP)			222-27569

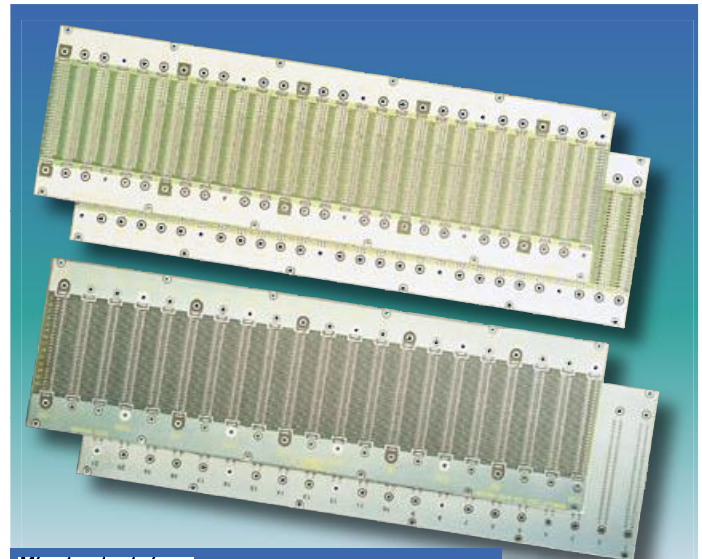

Microbus backplanes

GRAPH TEST DATA

- Temperature: 25°C
- Busbar width: 20mm
- Copper thickness width: 70µm
- Microbus typical impedance: 220Ω measured @1MHz
- DIN 41612 connector types B and C
- Power track resistance: less than 25mΩ/m, typically 19mΩ/m
- Signal track resistance: less than 1,2mΩ/m, typically 0,97mΩ/m
- Calculations based on both Vcc and 0V rails being used with single voltage

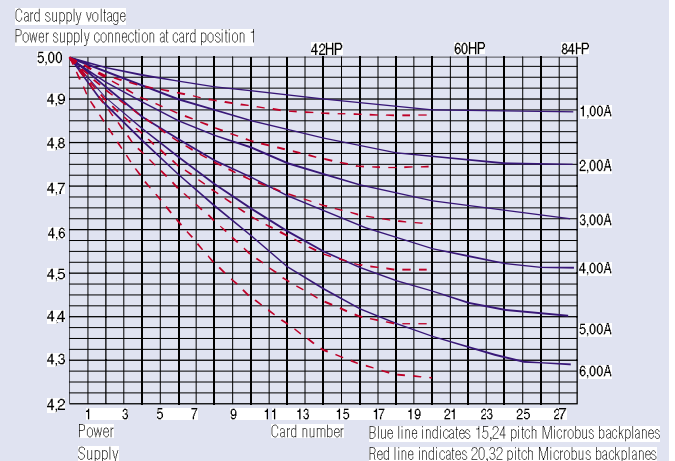

Results

96/96 way Microbus

Worst case in row c (square wave fed on row a) amplitude of crosstalk was 15% with only 8% on adjacent tracks in the same row.

64/96 way Microbus

Worst case in row c (square wave fed on row a) amplitude of crosstalk was 35% of main signal reducing further away from the main signal line. Adjacent tracks on the same row were 25-30% amplitude.

Board specification

Dielectric Epoxy glass	BS4584 , EP-GC-Cu3 FR4
Nominal thickness	1,6mm
Base copper thickness	35µm
Finish	
Plated copper	25µm average
Tin lead	8µm maximum
Total	68µm

*Note: bare boards are UL 94 V-0 recognised components file number E116551.
Bare boards are approved to BS9762*

Eurocard backplanes

Double sided uncommitted backplane

Features

- Total flexibility on positioning of Vcc or 0V
- Four voltage rails available
- M3 stud or 6,3mm Faston power connection facilities
- Choice of backplane widths and pitches
- High quality PTH boards with resist coating to prevent solder bridging

This range of backplanes has been designed to be totally flexible, allowing the engineer to configure the backplane to exactly match the requirements of his system. Each pin is bussed across the board, with the added facility of using row b as 0V guard rails thus minimising crosstalk on rows a and c. Power connection to the backplane is by means of M3 studs or 6,3mm Faston tabs. To identify voltages a combination of studs and Fastons may be used. Power commitment to pins 1, 2, 31 and 32, and other pins can be committed by either wirewrapping or hard wiring.

Double Sided Uncommitted Backplanes				Ordering information
Conn. type	Conn. pitch (HP)	Slots	Length x Width	Order code
96/96	20,32 (4HP)	21	128,6 x 420,8 mm	222-63630
96/96	20,32 (4HP)	10	128,6 x 197,3 mm	222-63631
96/96	20,32 (4HP)	5	128,6 x 95,7 mm	222-63632
96/96	15,24 (3HP)	28	128,6 x 425,9 mm	222-63633
96/96	15,24 (3HP))	14	128,6 x 212,5 mm	222-63634

Board specification

Dielectric Epoxy glass	BS4584, EP-GC-Cu3 FR4
Nom. thickness	1,6mm
Base copper thickness	35µm
Finish Plated copper	25µm average
Tin lead	8µm nominal
Total	68µm

*Note: bare boards are UL 94 V-0 recognised components file number E 116551.
Bare boards are approved to BS9762.*



Double sided uncommitted backplanes

“Vero Technologies also markets a range of DIN 41494 compliant 19” cardframes.

The VKM range is available in 3U and 6U heights and depths of 240mm or 360mm. Contact Vero directly for detail of pricing and availability”

Eurocard bus systems

Multilayer Microbus backplanes

This range of multilayer Microbus backplanes is available in 0,8" (20,32mm) and 0,6" (15,24mm) pitches. The 0,8" pitch versions have widths of 5, 10, 20 and 21 slots and the 0,6" pitch version is available in a single 20 slot width only. All widths coincide with either 42HP, 60HP or 84HP DIN41494 cardframes. All multilayer Microbus backplanes feature a patented tracking arrangement which includes 42 signal lines on each side of the board with a 0V guard track between each signal line. Power distribution is designed for use with a maximum of four power rails each capable of handling the total current rating of all connector pins, providing several feeders are used in order to distribute the load evenly.

Features

- 3 layer bonded multilayer construction with 0V ground plane sandwiched between signal layers
- Patented 0V guard tracking between all signal lines
- Theoretical characteristic impedance $Z_0 = 100\Omega \pm 5\%$
- Flexible power rail construction with up to four separate Vcc rails
- Fully assembled with 96/96 standard DIN 41612 compliant pin press-fit connectors and ample spade style power pick-up points
- 0,8 inch (20,32mm) and 0,6 inch (15,24mm) pitch versions
- Compatible with DIN41494 cardframes, multilayer extender boards and stub terminators

Multilayer Microbus Backplane				Ordering information
Slot pitch (HP)	No. of slots	Length x width	Cardframe width	Order code
20,32 (4 HP)	5	96 x 128	21HP	38-39104
20,32 (4 HP)	10	212 x 128	42HP	38-39105
20,32 (4HP)	15	303 x 128	60HP	38-39106
20,32 (4 HP)	21	425 x 128	84HP	38-39108

Board specification

Copper clad Epoxy glass board	BS4584
Nominal thickness	2,4mm
Copper thickness outer layers	38 μ m
Plated copper	37 μ m
Tin lead	5 μ m
Total	80 μ m
Copper thickness inner layers	38 μ m

Note: bare boards are UL 94 V-0 recognised components file number E 116551. Bare boards are approved to BS9762.

Characteristic impedance

The impedance of signal layers to the 0V ground plane with the signal track width of 0,38mm which gives a theoretical impedance of 100 Ω with a Z_0 tolerance of $\pm 5\%$.

Note: $Z_0 = 100\Omega \pm 5\%$ theoretical impedance excluding holes in the board
 $Z_0 =$ approximately 80 Ω including connector holes in backplane
 $Z_0 =$ approximately 20 Ω fully loaded with boards

Note: Manufactured under licence from University College, London

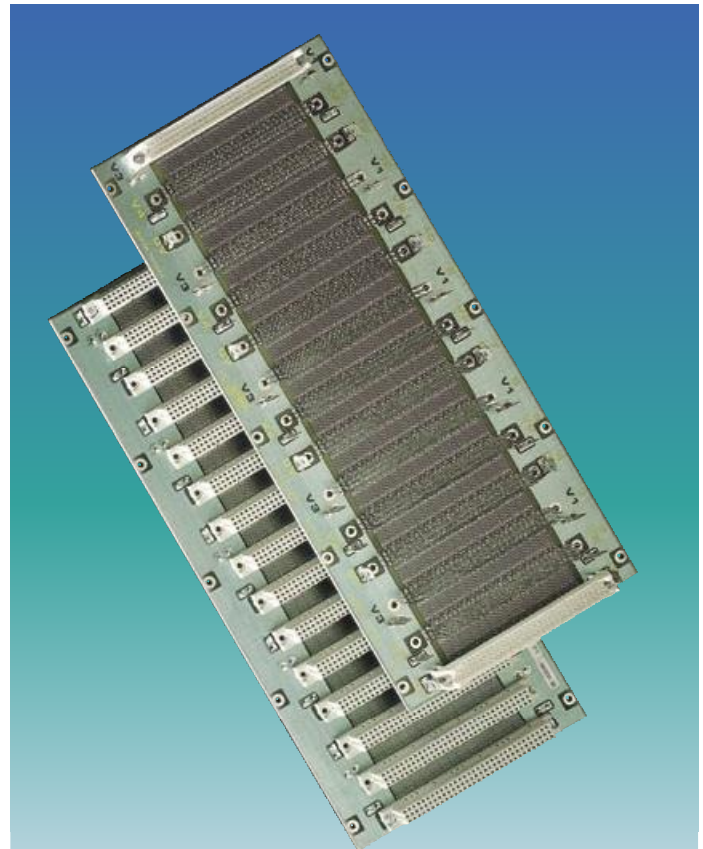

Multilayer Microbus backplanes

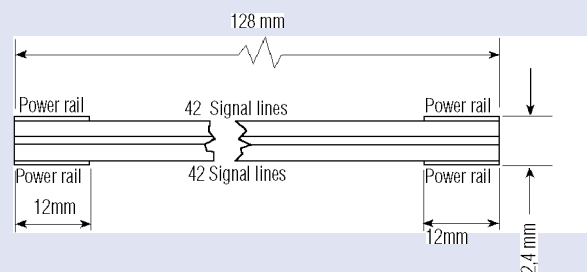

IBM PC Compatible I/O brackets

I/O Card Brackets

IBM brackets are available in various forms, with or without board fixing 'ears' with provision for different types of connector I/O, and are designed for fitting on either the component or solder side of the board. 20 bracket types are available ex-stock covering the most widely used applications. All brackets are manufactured from 0,80mm thick steel and finished in bright nickel plate.

I/O card brackets for IBM PC, PCXT and PCAT			Ordering information
Type	Description	PCB mtg. ctrs.	Order code
A	25 way "D"-Sub type	-	427-59693
B	9 way "D"-Sub type	-	427-59692
C	Twin phone type	73,7mm	427-59694
D	15 way "D"-Sub type	-	427-59695
E	37 way "D"-Sub type	-	427-59696
F	9 way & 25 way "D"-Sub type	-	427-59697
H	Blank panel: component side mounted	61,0mm	427-59699
J	Blank panel: no PCB mounting	-	427-59700
K	Blank panel: solder side mounted	88,9mm	427-59701
L	Blank panel: component side mounted	88,9mm	427-59702
M	37 way "D"-Sub type: solder side mounted	90,8mm	427-59703
N	Blank panel: solder side mounted	90,8mm	427-10036
P	50 way "D"-Sub type	-	427-10023
AA	15 way & 15 way "D"-Sub type	-	427-10027
BA	15 way & 25 way "D"-Sub type	-	427-10037
CA	15 way "D"-Sub type & BNC 12,8mm	-	427-10038
DA	25 way "D" type: solder side mounted	90,8mm	427-10039
EA	50 way Centronics	-	427-10040
FA	9 way "D"-Sub type: solder side mounted	90,8mm	427-10032
GA	9 way & 9 way "D"-Sub type	-	427-10041

Note: Fixing screws for I/O brackets with board fixing ears are available in packs of 100

Order code	427-56169
-------------------	------------------

PCI I/O Card brackets

To support the PCI products that are being introduced into the marketplace, APW is offering a range of PCI brackets. Nine brackets are available to cover the most widely used applications, and all brackets are manufactured from 0,80mm thick steel and finished in bright nickel plate.

PCI I/O Card Brackets			Ordering information
Type	Description	PCB mtg. ctrs	Order code
J	Blank bracket - no PCB mounting	-	427-59700
AB	25 way 'D' cut-out - no PCB mounting	-	427-314431
BB	9 way 'D' cut-out - no PCB mounting	-	427-314432
CB	Blank bracket - PCB mounting	85,39 mm	427-314433
DB	Blank bracket - with 4-40 PCB mounting	85,39 mm	427-314434
EB	Blank bracket - with M3 PCB mounting	85,39 mm	427-314435
FB	9 way 'D' cut-out - with 4-40 PCB mounting	85,39 mm	427-314436
GB	25 way 'D' cut-out - with 4-40 PCB mounting	85,39 mm	427-314437
HB	9 way 'D' cut-out - with 4-40 PCB mounting	85,39 mm	427-314438

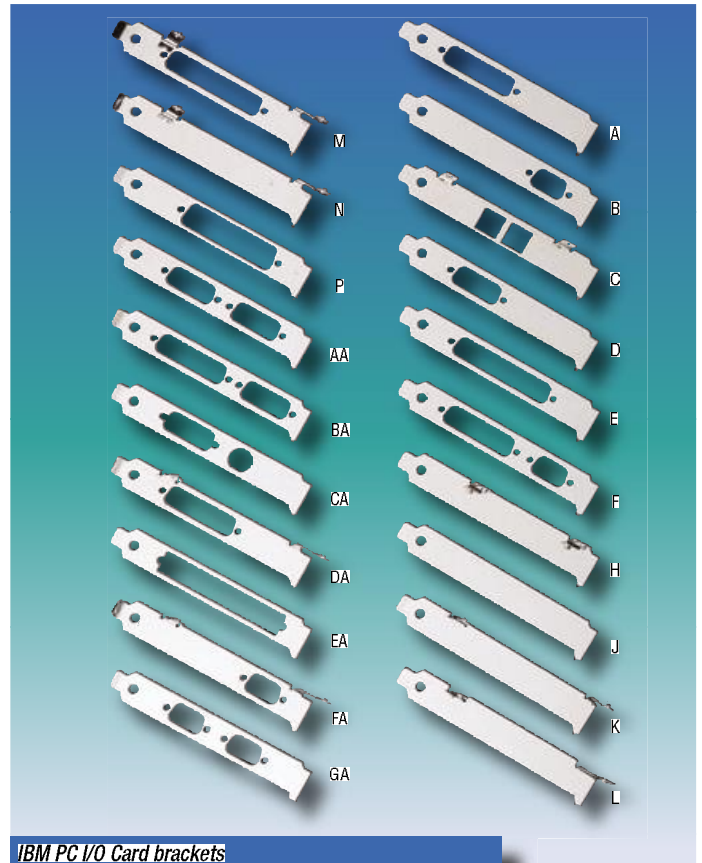

IBM PC I/O Card brackets

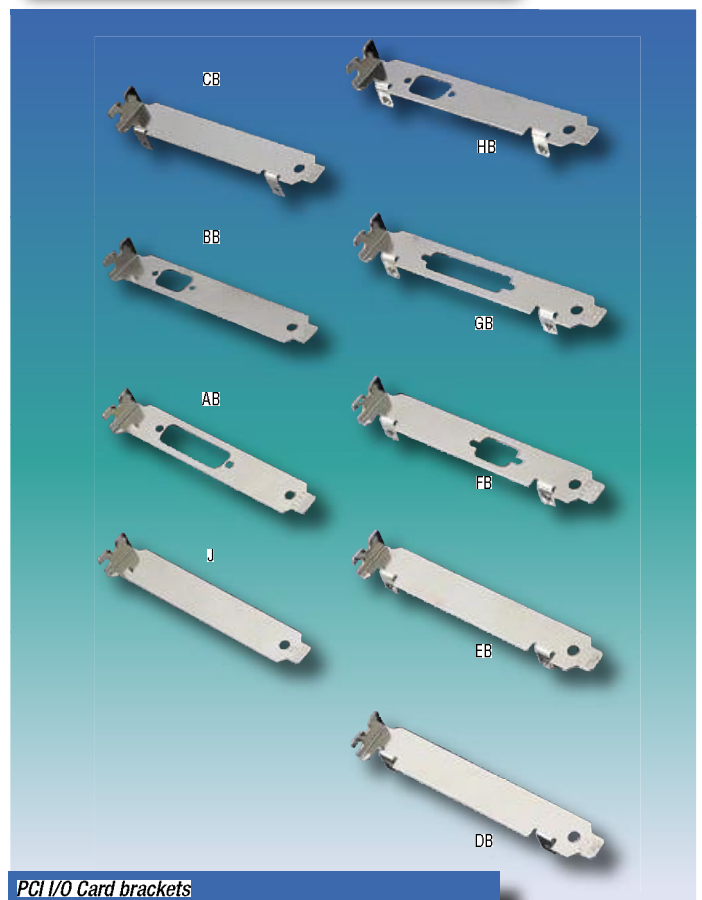

PCI I/O Card brackets

VEROWIRE and Prototyping Board Accessories

Verowire

The Verowire wiring system is ideal for prototypes, breadboards and limited production runs. Finished results are of a high standard with a neat orderly appearance achieved in significantly less time than more conventional methods.

Features

- Low profile
- High speed applications
- Suitable for high-density wiring
- No headers required
- Low cost

Wire specification

Diameter of wire:	0,20 mm (34 AWG)
Insulation:	Self-fluxing polyurethane*
Insulation Thickness:	0,005 mm
Proof Voltage:	600V d.c.
Current Rating:	0,100 A
Resistance @ 20°C:	0,857Ω/m
Length of wire/spool:	40 m
Colours:	Pink or Gold

Verowire	Unit of Sale	Ordering information
Description		Order code
Wiring pen	1	79-1732
Spools wire; 2 gold, 2 pink	4	79-19038
Spool wire, Pink	4	79-1737
Spool wire, Gold	4	79-1739
Wiring combs	100	79-1735
Half pin	1000	18-0223

Card support – ejector mechanism

Supplied as an accessory for any extender board, this device attaches to the end and guides/supports the circuit board under test. Supplied as a kit comprising 2 support – ejector assemblies, 4 M3 x 8 long screws and 4 M3 nuts.

Card support – Ejector mechanism	Ordering information
Description	Order code
Card support – ejector	22-2427

Spot face cutter

Used to break copper tracks on a PCB.

Can be used by hand or, with the handle removed, fitted into a bench drill

Spot Face Cutter	Ordering information
Description	Order code
Spot Face Cutter	22-0239

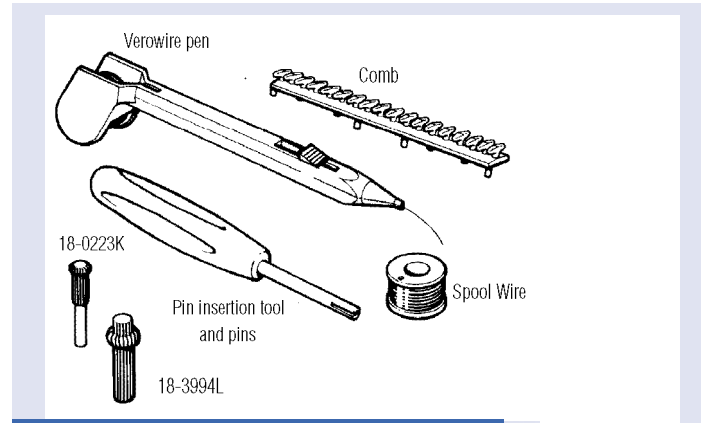

Verowire Accessories

WARNING!

When soldering through polyurethane enamelled wire a small quantity of TDI gas is produced. Use in a well ventilated room.

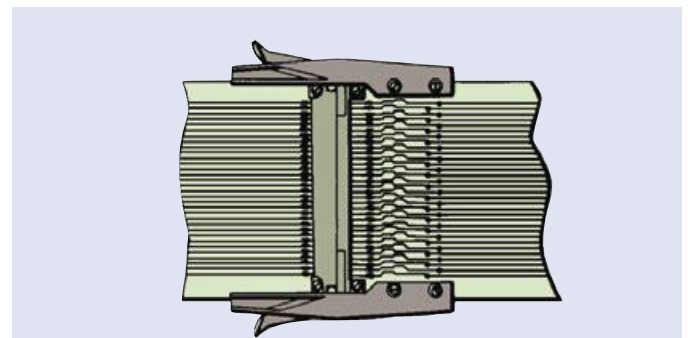

Card Support – Ejector Mechanism

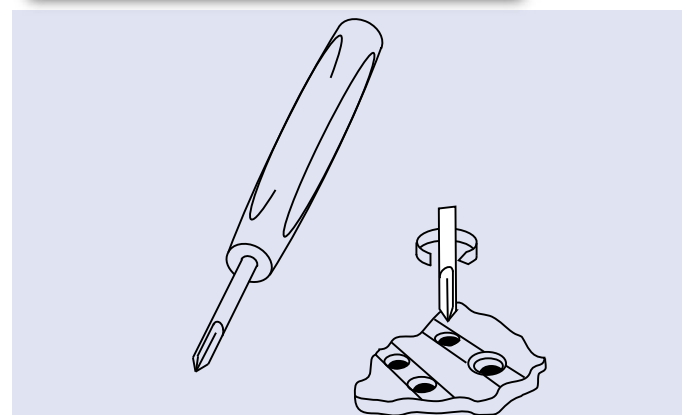

Spot Face Cutter

Prototyping board accessories: terminal pins

Terminal assembly (Type 8)

This assembly is designed to act as a terminal on PC boards for attachment of scope probe etc. The spring design allows the terminal to be inserted into a plated through hole board without damaging the hole plating. The terminal will remain in place when the board is reversed for soldering. The sintered glass bead has a recommended maximum working temperature of 475°C. Assemblies are available for two different hole diameters. The terminal assemblies are available in five standard colours; black, yellow, red, white or green.

Nominal hole Ø	Dim. A (mm)	Dim. B (mm)	Dim. C (mm)
1,0 ±0,1	1,1 - 1,3	3,1 - 3,3	2,3 - 2,5
1,4 ±0,2	2,0 - 2,2	2,9 - 3,1	3,2 - 3,4

Terminal Assemblies	Ordering information	
Colour	Nominal hole Ø 1,0mm ±0,1	Nominal hole Ø 1,4mm ±0,2
Red	20-313137	20-313141
Green	20-313138	20-313142
White	20-313139	20-313143
Yellow	20-313140	20-313144
Black	20-2137	20-2136

Supplied in packets of 100

Material Specifications

Sintered Glass Bead	
Bead material	Boro Silicate Sintered Glass
Properties	Loss angle at 1MHz (20°C) 5,7 / 0,003

Wire Loop

Material	Phosphor Bronze (BS2873) PB102 Cu Sn5	
Composition (weight %)	Sn	4,5 – 5,5%
	P	0,02 – 0,40%
	Cu	rem.
Plating	Electroplated Bright Tin	3,0 – 5,0 micron

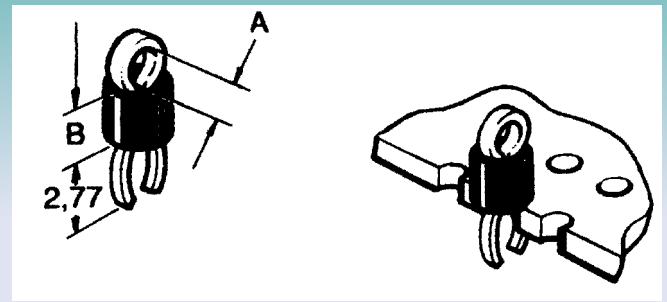
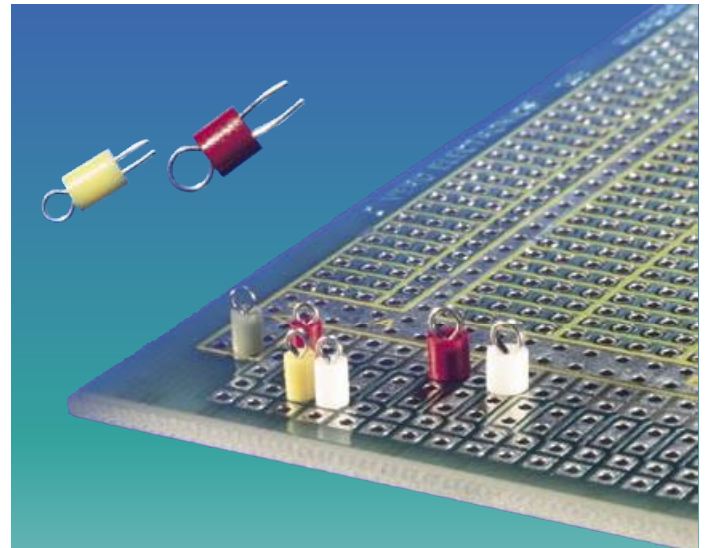

Terminal Assembly

Prototyping board accessories: headers and socket pins

Miniwrap socket pins (Types 3 & 4)

These pins have 4-leaf spring beryllium copper inserts enabling components to be plugged directly into sockets.

Type 3 is a low-profile pin allowing components to be mounted close to the board surface

Type 4 has a higher profile allowing heat to be dissipated by convection between the components and the board

Material: All wire wrapping pins are manufactured from brass to BS249 and gold plated over a copper and nickel finish (unless otherwise stated)
Post size: 0,61 mm square, 0,86 mm diagonal.

Socket pins - typical test data
(test data shown applies to 66-3472C and 66-3505A only)

Test	Result
Terminal retention	5,4 kgf
Contact resistance	Initial 5,3mΩ average After 1000 insertions /withdrawals 6,4 mΩ av.
Low voltage	0,1 mA measured with open-circuit voltage of 10μV
Salt spray (48 Hours)	Contact resistance <15Ωm No evidence of galvanic corrosion
Humidity	No evidence of damage
Exposure to atmospheric pollution	5mΩ maximum

Miniwrap Socket Pins		Ordering information
Type	Compatible hole Ø pierced/drilled	Order code
3	-1,45	66-3472
4	1,02/1,05	66-3505

Miniwrap headed pins (Type 2)

For mounting discrete components.

These pins feature a 0,89 mm cross-cut slot on the component side to locate component leads for assembly.

Miniwrap Headed Pins		Ordering information
Type	Compatible hole Ø pierced/drilled	Order code
2	1,02/1,05	66-3523

Supplied in packets of 100

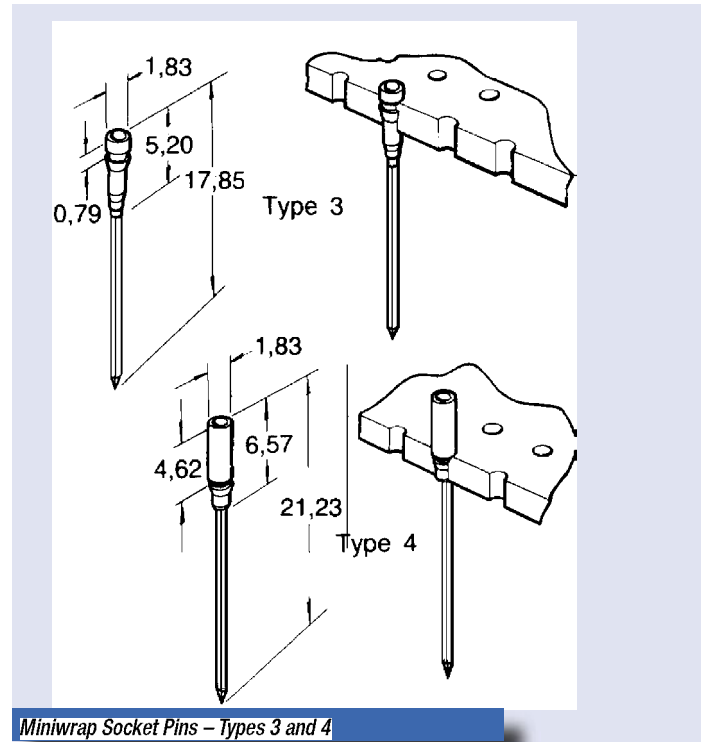

Miniwrap Socket Pins – Types 3 and 4

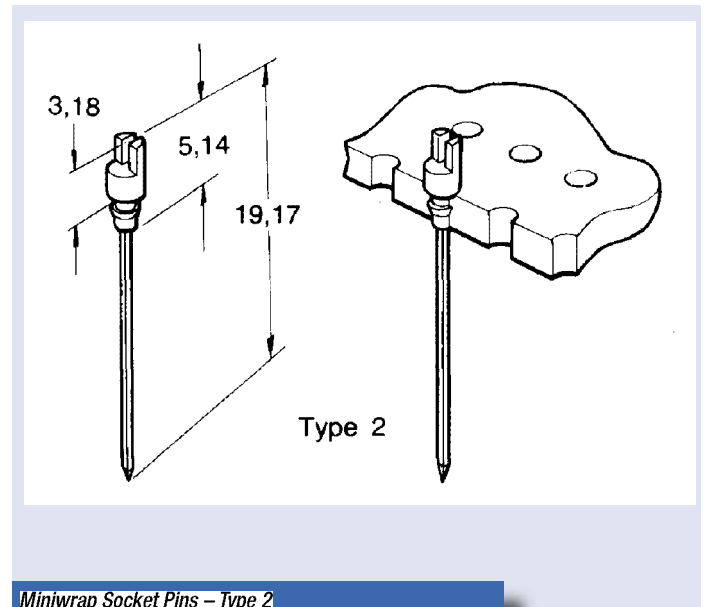

Miniwrap Socket Pins – Type 2

Prototyping board accessories: headers and socket pins

Terminal header pin (Type 7)

May be mounted directly into header board or alternatively plugged into socket pins (66-3472 - type 3) or (66-3505 - type 4).

Terminal Header Pin		Ordering information
Type	Compatible hole Ø pierced/drilled	Order code
7	1,02/1,05	66-3469

Supplied in packets of 100

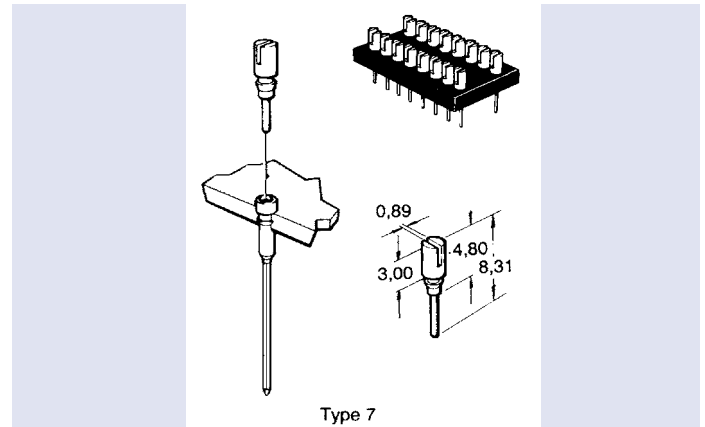

Terminal Header Pin – Type 7

Miniwrap terminal pin (Type 9)

Suitable for use with all types of boards. This pin may be soldered to a copper track or pad to ensure electrical continuity.

Terminal Header Pin		Ordering information
Type	Compatible hole Ø pierced/drilled	Order code
9	1,02/1,05	66-3514

Supplied in packets of 100

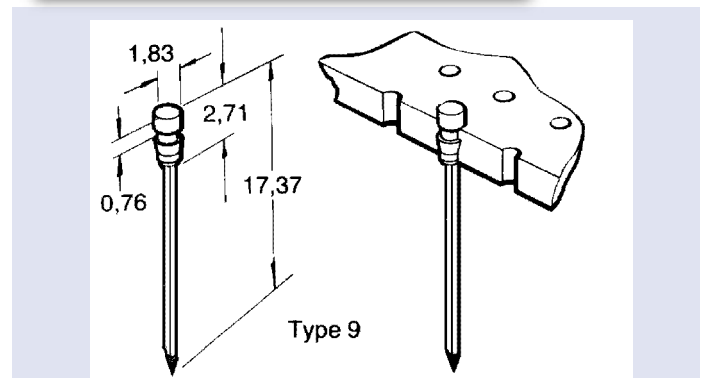

Miniwrap Terminal Pin – Type 9

Test point pins (Type 12)

These pins feature a turreted lug on the component side, guaranteeing a firm connection using a clip-on style test probe.

Test Point Pin		Ordering information
Type	Compatible hole Ø pierced/drilled	Order code
12	1,32/1,40	66-3532

Supplied in packets of 100

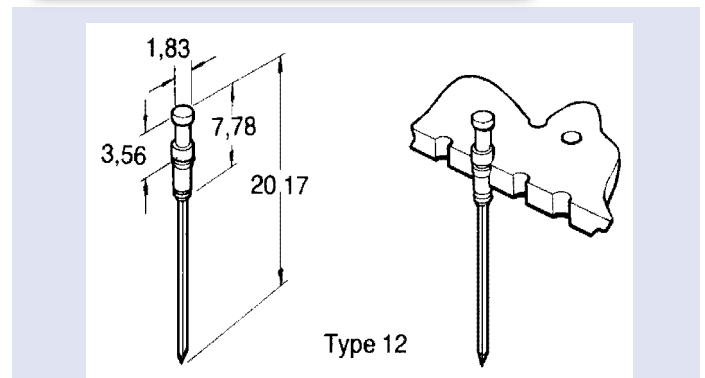

Test Point Pins – Type 12

Prototyping board accessories

Single sided pin (Type 10)

For use with plain or copper-clad boards. These pins have the facility for soldering discrete components on one side and wire wrapping on the other.

Material: Manufactured from phosphor bronze to BS 2870 PB 102 with tin finish over copper flash.

Post size: 0,68 mm x 0,64 mm, diagonal 0,94 mm

Single Sided Pin		Ordering information
Type	Compatible hole Ø pierced/drilled	Order code
10	1,00/1,05	18-0226

Supplied in packets of 500

Double sided pin (Type 11)

For use when wirewrapping is required both sides of the board.

Double Sided Pin		Ordering information
Type	Compatible hole Ø pierced/drilled	Order code
11	1,00/1,05	18-1657

Supplied in packets of 500

Solder terminal pin (Type 2)

By inserting pin up to its shoulder these pins stand at a fixed height above the board surface. The separated profile offers good mechanical retention while electrical contact is made by soldering shoulder to copper track.

Available in two sizes for hole size 1,02 and 1,32 mm.

Solder Terminal Pin		Dimensions					Ordering information
Hole dia.	A	B	C	D	E	Order code	
1,00	9,7	5,6	1,1	1,0	0,4	18-0222	
1,32	11,9	6,7	1,4	1,2	0,5	18-0219	

Supplied in packets of 1000

Solder terminal pin (Type 3)

Similar to 18-0222D but manufactured from phosphor bronze to BS 2873 PB 102, tin finish over copper flash.

Solder Terminal Pin		Ordering information	
Type	Qty	Hole dia.	Order code
3	1000	1,00	18-0218

Solder terminal half pin (Type 4)

These pins are ideally suited to take off points or flying leads from a PCB. The shoulder is soldered to the copper track with the pin protruding on the component side of the board. Two sizes are available for 1,02 and 1,32 mm diameter holes.

Solder Terminal Half Pin		Ordering information		
Type	Qty	Hole dia.	Dim.A	Order code
4	1000	1,32	1,21	18-0217
4	1000	1,00	0,93	18-0223

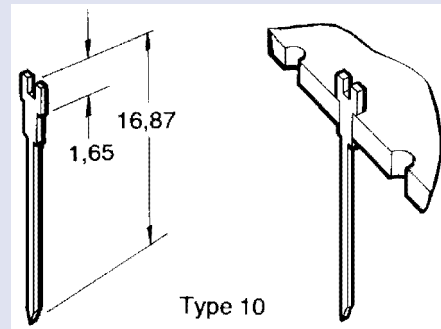

Type 10

Single Sided Pins – Type 10

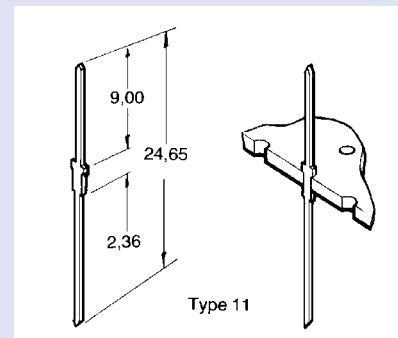

Type 11

Double Sided Pins – Type 11

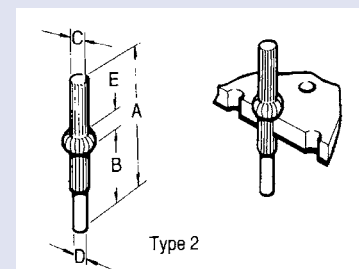

Type 2

Solder Terminal Pins – Type 2

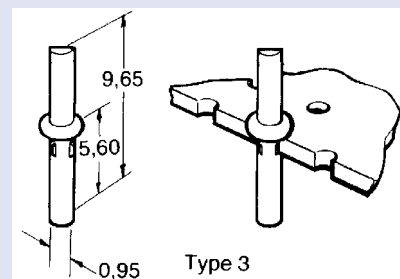

Type 3

Solder Terminal Pins – Type 3

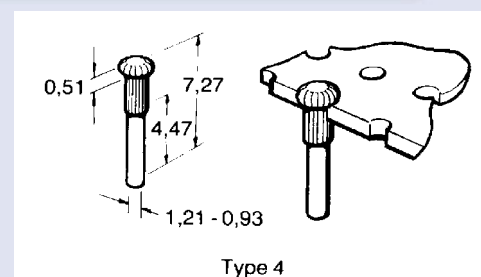

Type 4

Solder Terminal Half Pins – Type 4

Prototyping Boards and Accessories: Part Number Index

01		18		222	
01-0014	11	18-0217	24	222-2470	16
01-0021	11	18-0218	24	222-2991	4
01-0040	11	18-0219	24	222-2992	4
01-0041	11	18-0222	24	222-2993	4
01-0042	11	18-0223	20	222-2994	4
01-0043	11	18-0223	24	222-22847	16
01-0112	11	18-0226	24	222-26025	16
01-0171	11	18-1657	24	222-26492	4
01-027567	11			222-27569	16
01-027568	11			222-53134	4
02		20		222-53135	4
02-0134	12	20-2136	21	222-53136	4
03		20-2137	21	222-63630	17
03-0026	7	20-313137	21	222-63631	17
03-0111	7	20-313138	21	222-63632	17
03-02989	7	20-313139	21	222-63633	17
03-02990	7	20-313140	21	222-63634	17
03-27555	7	20-313141	21	427	
03-27556	7	20-313142	21	427-10023	19
03-27557	7	20-313143	21	427-10027	19
06		20-313144	21	427-10032	19
06-0147	9	22		427-10036	19
06-0166	12	22-0239	20	427-10037	19
06-0168	12	22-02427	20	427-10038	19
07		38		427-10039	19
07-0008	11	38-39084	14	427-10040	19
09		38-39104	18	427-10041	19
09-0106	13	38-39105	18	427-56169	19
09-0108	13	38-39106	18	427-59692	19
09-1034	10	38-39108	18	427-59693	19
09-1036	9	38-61486	15	427-59694	19
09-1040	10	38-63623	15	427-59695	19
09-1461	10	66		427-59696	19
09-2196	8	66-3469	23	427-59697	19
09-2459	13	66-3472	22	427-59699	19
09-2460	13	66-3505	22	427-59700	19
09-3817	13	66-3514	23	427-59701	19
09-3865	13	66-3523	22	427-59702	19
09-19082	10	66-3532	23	427-59703	19
09-27562	8	67		427-314431	19
10		67-1902	11	427-314432	19
10-0581	6	79		427-314433	19
10-1041	8	79-1732	20	427-314435	19
10-1042	8	79-1735	20	427-314436	19
10-2446	5	79-1737	20	427-314437	19
10-2449	5	79-1739	20	427-314438	19
10-2845	5	79-19038	20	188	
10-2858	5	188		188-27542	14
10-3183	8	188-27542	14		
10-27558	6				
10-27563	5				

SpeedPanel

The FAST front panel service from Vero Technologies standard 3 week guaranteed turnaround, or super-fast 72-hour service

Vero Technologies has installed a sophisticated integrated manufacturing cell dedicated to front panel production. Using the latest technology in high-speed DNC routing and engraving, together with in-house silk screen printing, the SpeedPanel 72 service can offer a fast 72-hour turnaround from receipt of suitable CAD data. For longer runs, a guaranteed 3-week service is provided.

Front panel furniture, such as handles, plastic or metal retaining inserts etc., can be supplied as a kit or ready assembled. Front panels can be custom manufactured to suit your requirements. Options can include machined pockets as well as cut-outs, all manufactured to tight tolerances. Ideally, CAD data should be provided, but our engineers can develop a bespoke programme from a hard-copy drawing.

Features

A 'one-stop-shop' for total front panel manufacture, providing:

- All types and sizes of front panel including 19" standard panels, EMC shielding, cPCI panels with EMC gaskets and PMC bezels
- Multi-colour printing including logos
- Engraving
- Protective overlays with cutouts available in multiple colours – for high finger traffic applications
- Wide range of complementary accessories – card handles, injector-ejector handles for IEEE1101.10 and .11, and screw mounting kits etc.

Front Panel Types

All panels are manufactured from 2,5mm aluminium.

Type 1	Front panel of any size with horizontal grain, 'silver' anodising on the front and rear faces, with machined surfaces untreated
Type 2	Front panel horizontal grain with anodised front surfaces only, all other surfaces finished with Alochrome 1000. Metal inserts can be provided as part of the front panel handle kit
Type 2	cPCI (IEEE1101.10) EMC shielded, vertical grain, in 2U or 6U heights with horizontal widths of 4HP or 8HP. Supplied with an EMC shielding gasket
Type 4	PMC bezels made from solid aluminium or die-cast, supplied with conductive O rings

Finishes

Type 1 has pre-anodised Aluminium on both the front and back faces with the cut edges – which are not seen – unanodised. To provide a conductive finish on the machined surfaces Alochrome 1000 or Alochrome 1200 can be specified as an option.

Printing

In addition to screen print finishes, both engraving and UV ink printing options are available for notation and logo reproduction. Engraved material is based on a selection of standard fonts, such as Arial. Other fonts can be reproduced provided they form part of the CAD data, and are contained on a separate layer. As standard, all engraving is in black, giving a permanent and hard-wearing finish.

Colour printing using UV inks is based on a four colour Pantone pallet. This achieves good reproduction of complex, multi-coloured company logos. In order to print in more than one colour, a .pdf or .jpg file of the image is required.

The ident strips on the front panel handles can also be printed in multiple colours

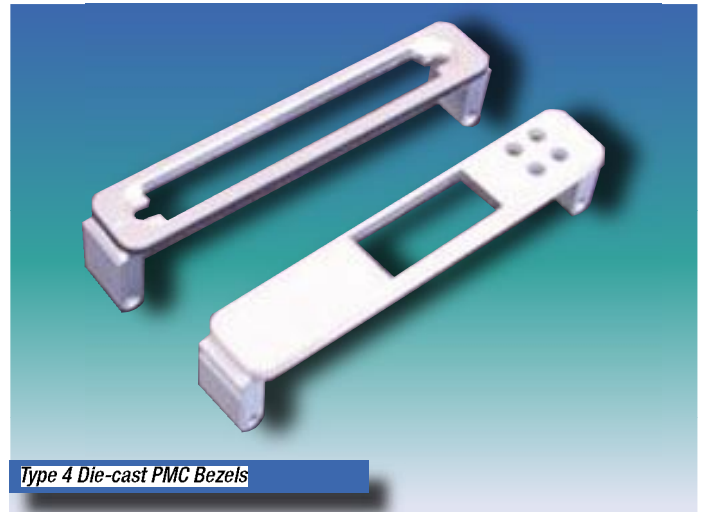

Type 4 Die-cast PMC Bezels

Accessories

A range of front panel handle types can be provided:

- Standard plastic handle kits containing
 - Handle, ident strip, screws and retaining inserts
- Injector-Ejector handles to IEEE1101.10 and .11
 - Aluminium handle, ident strip, metal screws and retaining inserts to ensure good conductivity

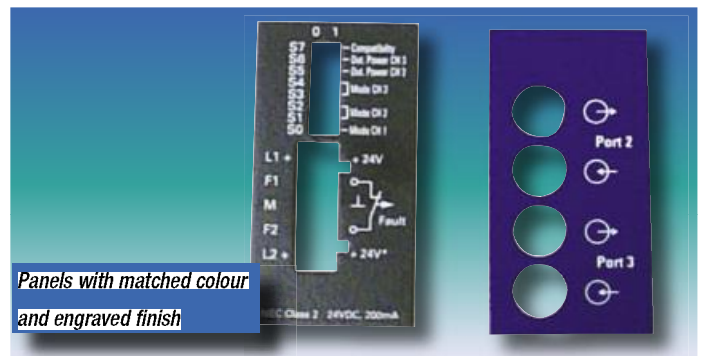

Panels with matched colour and engraved finish



Type 2 panel with alochrome finish – detail

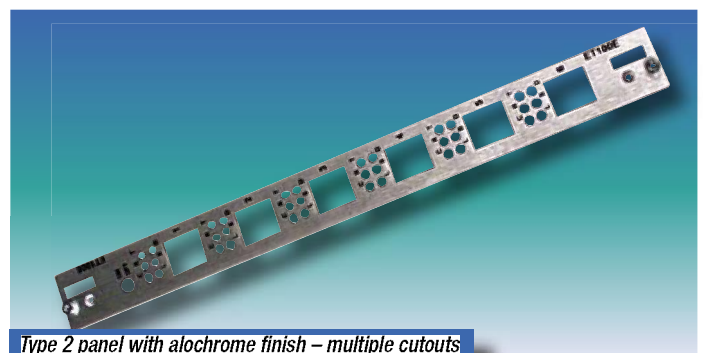

Type 2 panel with alochrome finish – multiple cutouts

SpeedPanel

Lead Time

Vero Technologies offers a choice of two lead times for front panel production.

- SpeedPanel 72, ensuring despatch 72 hours after receipt of correct manufacturing data. A CAD drawing is required for this lead time. There is a premium for this service.
- SpeedPanel – a consistent, 3-week guaranteed lead-time from receipt of correct manufacturing data. This service allows customers to have the confidence to order for stock via their ERP systems.

File Types

Manufacturing data for metalwork, screen printing and company logos can be accepted in the following formats:

	.dwg	.dxf	.ai	.eps	.ps	.jpg	.pdf
Metalwork	✓	✓					
Silk Screen	✓		✓	✓	✓	✓	✓
UV Colour			✓	✓	✓	✓	✓

Design Service

Our design engineers can assist in providing technical input into new developments, and can – if required – create CAD data from existing, dimensioned, hard-copy material.

Ordering SpeedPanel

To order front panels manufactured to SpeedPanel 72, or standard SpeedPanel timeframes, send an email to sales@verotl.com with the relevant CAD information and details of the following:

- Finishes required
- Suitable e-files
- Accessories required; front panel handles, injector–ejector handles etc.
- Quantities per part number
- Lead-time required – 72 hours or three weeks

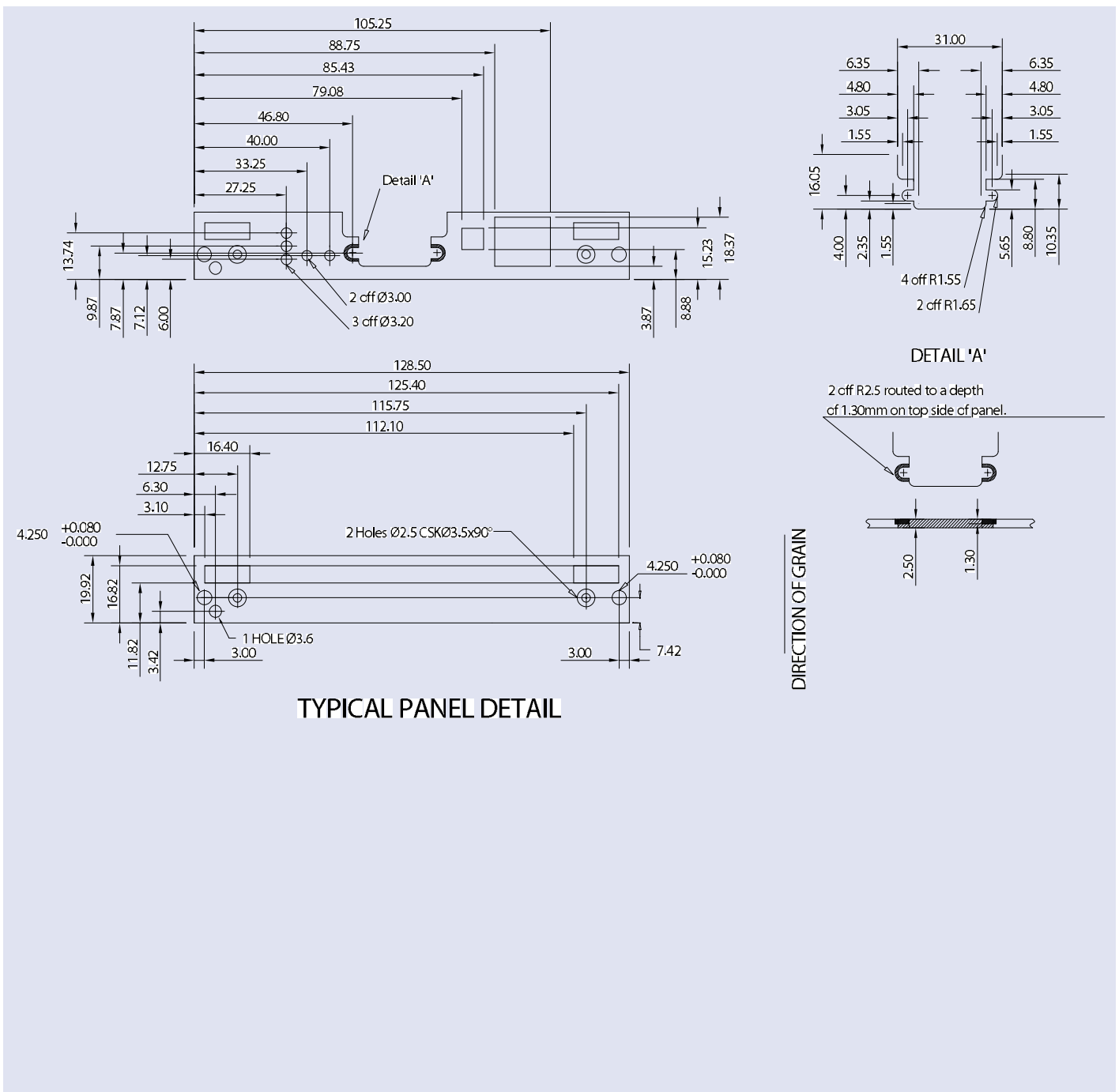

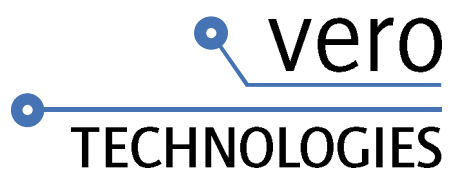

Vero Technologies Limited

Unit 25, Solent Trading Estate, Shamblehurst Lane, Hedge End, Hants, SO30 2FY

• +44 (0)1489 776931 telephone • +44 (0)1489 776938 fax • sales@verotech.co.uk email •

sales: +44 (0)87 0225 9505 internet: www.verotl.com